

WATER ABSORBING OFF-LINE FILTERS

RMF Systems

*The guarantee
of
problem free
hydraulics*



OLUW 1A30



OLUW 1B30

RMF SYSTEMS

RMF Systems radial micro filter units are characterised by their extremely efficient filter elements with a fineness of 0.5 micron.

Specially designed for industrial hydraulic installations the RMF Off-line filters are available in single or multiple housing configurations. The Off-line filter units can easily be mounted to new and existing hydraulic installations.

By means of an integrated pump-motor unit in the Off-line filter, the oil is pumped from the reservoir through the filter unit and after filtering the oil is then returned to tank.

ECONOMICAL

The hydraulic market accepts that 80% of mechanical failures are caused by contamination in the system.

The RMF Water Absorbing Off-line filters attack this contamination at source and in addition to solid particles, these filters are also capable of removing large quantities of water from the oil.

This prevents the catalytic reaction of water and solid particle contamination, resulting in extended useable oil life. The use of RMF filters means less defects, less maintenance and less wear of the hydraulic components.

WATER ABSORBING

RMF Water absorbing filters are Off-line filters that use special water absorbing spin-ons as a pre-filter. The fluid is pumped through the pre-filter which removes most water and larger solid contamination, in the second stage the fluid passes through the RMF micro filter where final water removal takes place as well as solids removal down to 0.5 micron.

In recent years RMF Systems have developed a great deal of experience in cleaning and drying hydraulic and lubrication systems in the:

- steel industry;
- maritime industry;
- petrochemical industry;
- paper industry.

ADVANTAGES

- Extremely clean oil due to the high filtration efficiency $\beta_{0.5} \geq 200$, $\beta_2 \geq 2,330$.
- Prevention of channel forming by radial filtration direction.
- Increased flow capacity.
- Increased dirt holding capacity.
- Large water holding capacity.
- Compact and easy-maintenance design.
- Longer usage life for oil and components.



www.rmfilter.com

WATER ABSORBING OFF-LINE FILTERS

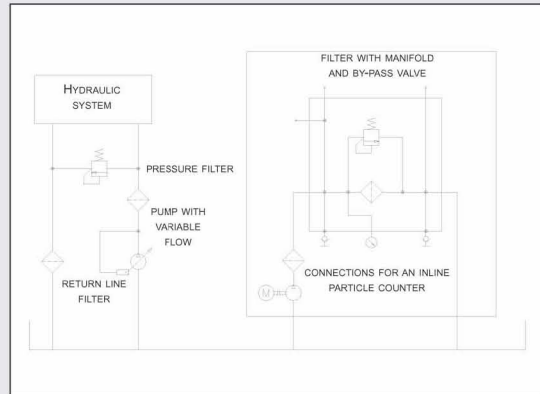
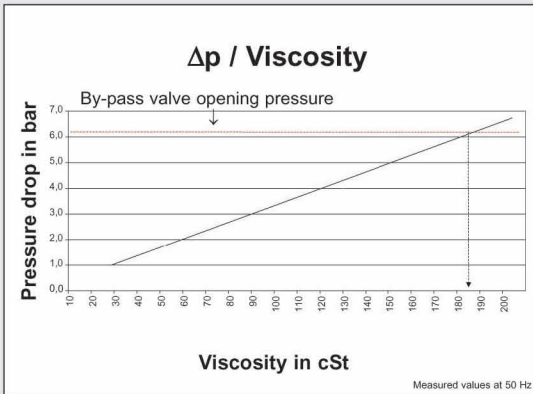
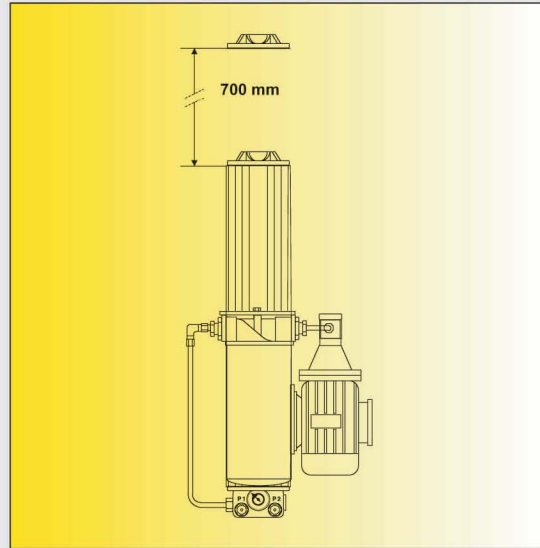
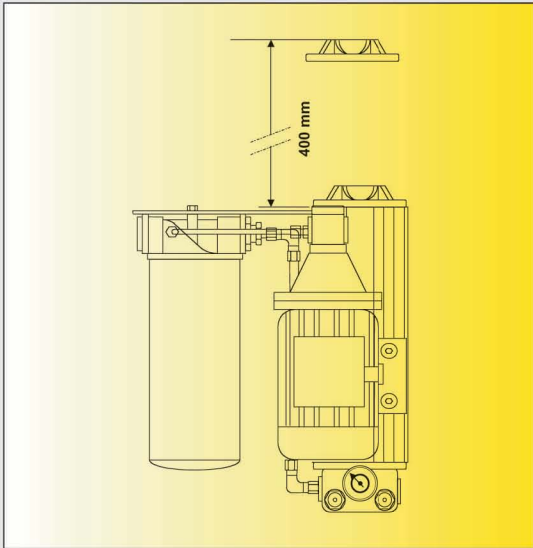

Technical data		
Type filter	OLUW 1A30	OLUW 1B30
No. of filter housings	1	1
Material filter housing	Anodised aluminium	
Seal material	Buna-N standard	
Nominal flow standard	2.1 l/min	4.2 l/min
By-pass opening pressure	±6.2 bar (0 bar back pr.)	
No. of std. filter elements	1	2
No. of water absorbing elem.	1	1
Water absorbing capacity	650 ml	800 ml
Max. pressure filter housing	20 bar	
Max. oil temperature	80 °C	
Max. viscosity	180 cSt	
Indicator type	Gauge glycerine filled	
Connection pump suction	3/8" BSP female	1/2" BSP female
Diameter hose suction side	1/2"	
Filter return connection	1/2" BSP female	
Diameter hose return side	3/8"; (1/2" with long hoses)	
Dimensions hxwx d (mm)	400 x 360 x 330	710 x 410 x 320
Pump type	Gear pump	
Power supply E-motor	Various electrical power supplies possible	
Max. tank volume (litre)	ca. 1,350	ca. 2,700
Standard units for larger tank volumes are also available		
Connection oil-analysis:		
P1 filter inlet side	Test connector (M16x2) Red	
P2 filter outlet side	Test connector (M16x2) Yellow	

Your RMF Systems distributor

SE HYDRAULICS

FLUID POWER ENGINEERS

www.seh-ltd.co.uk

R.01-04/1GB

KOPPEN & LETHEM

Produced by and copyright: Koppen & Lethem Aandrijftechniek B.V., Waddinxveen, The Netherlands
Tel. +31 182 62 54 62, info@koppen-lethem.nl, www.koppen-lethem.nl. *Subject to change!*