

Industrial Piston Accumulators

**CE Approved Accumulators & Gas Bottles
for working pressures up to 350 bar**

*Catalogue HY07-1240/UK
January 2001*



Parker – Your Single Source Supplier for Accumulator Products



▲ Bladder accumulators for working pressures up to 420 bar – ask for catalogue 1235-1/UK

Forged-end auxiliary gas bottles – see page 6 ▼



Accumulator Safety Blocks for working pressures up to 350 bar – ask for catalogue 1241-1/UK ▼



▲ Rack-mounted accumulator with auxiliary gas bottles – see pages 27 and 35

UCA Charging and Gauging Kit – ask for Bulletin 1235-M1/UK ▼



Introduction

Contents	Page
Introduction	
Applications and Certification	5
Accumulator Selection	6
Auxiliary Gas Bottles	6
Section 1 – A Series Piston Accumulators	
Introduction	7
Specification	8
Features and Benefits	9
250 Bar Models – Capacities and Dimensions	10
– Ports and Seals	11
350 Bar Models – Capacities and Dimensions	12
– Ports and Seals	13
Options, Spares and Accessories	14
Model Numbers and How to Order	16
Section 2 – AP Series High Performance Piston Accumulators	
Introduction	17
Specification	18
Features and Benefits	19
250 Bar Models – Capacities and Dimensions	20
– Ports and Seals	21
350 Bar Models – Capacities and Dimensions	22
– Ports and Seals	23
Options, Spares and Accessories	24
Model Numbers and How to Order	26
Section 3 – B Series Gas Bottles	
Introduction	27
Specification	28
Features and Benefits	29
250 Bar Models – Capacities and Dimensions	30
350 Bar Models – Capacities and Dimensions	31
250 and 350 Bar Models – Ports	32
Options, Spares and Accessories	32
Model Numbers and How to Order	34
Section 4 – BP Series Gas Bottles	
Introduction	35
Specification	36
Features and Benefits	37
250 Bar Models – Capacities and Dimensions	38
350 Bar Models – Capacities and Dimensions	39
250 and 350 Bar Models – Ports	40
Options, Spares and Accessories	40
Model Numbers and How to Order	42
Section 5 – Sizing Information	
Sizing Charts and Calculation	43

Section 1

Section 2

Section 3

Section 4

Section 5

Our Commitment to Quality and the Environment

Parker's piston accumulators are constructed in modern, purpose-built operations at manufacturing sites across the world. A programme of continuous investment has created state-of-the-art production facilities which underline our commitment to quality and acknowledge our responsibility for the environment. Our accumulator facilities have, or are working towards, ISO 14001 certification, guaranteeing that all aspects of production meet stringent environmental standards from the beginning to the end of the production process.

Pistons, shells and end caps are individually inspected before assembly, while seals and bearing rings are hand-fitted to ensure precise location. Following assembly, the oil and gas sides of each accumulator are pressure-tested to 1.5 times maximum working pressure, and held at this level to test seal integrity.



Parker Hannifin Corporation . . .

is a world leader in the manufacture of components and systems for motion control. Parker has more than 800 product lines for hydraulic, pneumatic and electro-mechanical applications in some 1200 industrial and aerospace markets. With over 40,000 employees and some 200 manufacturing plants and administrative offices around the world, Parker provides its customers with technical excellence and first class customer service.

Catalogues describing our standard products are available from your nearest Parker sales office – please see the rear cover of this catalogue for details, or visit us at www.parker.com. Where an application demands a non-standard approach, special products can be designed to order – our engineers will be pleased to advise.



Cleaning processes during production and prior to final painting use water-based solvents in a closed cycle. The fluid used for pressure testing is continuously filtered and recycled, and the flush cycle incorporates on-line dynamic fluid sampling of the purged oil using laser particle counting to monitor cleanliness levels.

The computer-controlled test sequences enable a performance profile of each individual accumulator to be built up and compared to production norms. The standard paint finish for piston accumulators is a water-based primer, with other finishes to the customer's own specification available to special order.

Design and manufacturing processes are certified to ISO 9001, to ensure full traceability and provide a continuous guarantee of the quality of our workmanship.

Note: In line with our policy of continuing product improvement, specifications in this catalogue are subject to change without notice.

Hydro-Pneumatic Piston Accumulators

Parker's piston accumulators provide a means of regulating and optimizing the performance of a hydraulic system. They are used in a wide range of industrial and mobile applications to reduce energy consumption, protect system components and prolong equipment life, reducing downtime and maintenance requirements. Their simple, compact design ensures dependable performance with maximum efficiency and service life.

Why use a Piston Accumulator?

- Provides a practical and cost effective method of delivering large volumes of fluid at high speed.
- Provides an auxiliary power source by storing power for use during peak demands. The resulting smaller pumps, motors and reservoirs reduce installation and operating costs.
- Protects hydraulic systems and components from damage due to thermal expansion and contraction in a closed system.
- Compensates for changes in fluid volume to maintain a positive pressure.
- Reduces costly damage to hoses, fittings and gauges by absorbing hydraulic line shocks.
- Progressive failure mode protects operators and equipment in safety-critical applications.
- Supplies emergency fail-safe power to complete a work safety cycle in the event of pump or electrical failure.
- Maintains high pressure for long periods while preventing oil overheating, reducing pump wear and saving energy.
- Can be mounted in any attitude without loss of performance.

Typical Applications Include . . .

- Die casting and injection moulding – providing high working pressure with instantaneous flow rates during rapid cycling.
- Machine tools – to maintain pressure and reduce pump size.
- Piston and diaphragm pumps – reducing pump pulsations.
- Hydraulic press operation – providing the high flow rates necessary for rapid pressure rise.
- Offshore applications – as a source of emergency power for safety and shut-down systems.
- Winches – maintaining line tension.
- Paper-making machinery – maintaining guide and backing roller position and pre-load.



Certification

Accumulators and gas bottles are pressure vessels which are subject to the safety laws and regulations of the country in which they are operated. In addition, other industry-specific regulations may apply in applications such as shipbuilding, aviation etc.

European Pressure Equipment Directive

Prior to the adoption of the Europe-wide CE approval for pressure vessels, many European member states operated their own approvals systems, eg: TÜV in Germany, DRIRE in France, ISPEL in Italy etc. With the introduction of the Pressure Equipment Directive (97/23/EC) which has been optional since November 1999 and becomes mandatory on the 29th May 2002, users of accumulators can opt for the new CE approval in place of existing national standards.



CE approval incorporates the requirements of all existing national approvals, enabling an approved pressure vessel to be used in any European Union member state without the need for local approval.

CE Approved Accumulators and Gas Bottles

Parker's piston accumulators and gas bottles are available with certification to the new CE approval, recognized and accepted in all European Union member states.

- Maximum working pressures – 250 and 350 bar
- Volumes – up to 300 litres
- Shell temperature range from -10°C to +150°C
- Fluids and seals – a comprehensive range of seal compounds is available, to suit different fluids and operating conditions.
- Ports – flanged or threaded ports in metric sizes are supplied as standard – other styles on request.
- Precharge – units can be shipped pre-charged, to customer specification.

Accumulator Selection

Parker offers two ranges of piston accumulators for industrial use, the A and AP Series, to suit different application and performance criteria. Each is described in a separate section of this catalogue. The table below provides a brief summary to assist in initial selection.

Accumulator Selection Guide

Series	Standard Approval	Max. Working Pressure	Fluid Capacity litres	Bore Dia.	Interface	Page
A	CE	350	0.1-38	50-150mm 2-6 in.	Metric & Inch	7
AP	CE	350	6-300	180-360mm	Metric	17

In addition to the industrial piston accumulators featured in this catalogue, Parker also offers a comprehensive range of bladder accumulators – see Catalogue no.1235, and piston accumulators for mobile applications – see Catalogue no.1245.

A Series Piston Accumulators

The A Series range of accumulators is designed for general purpose applications where piston speeds and flow rates are relatively low, such as in power units, pressure maintenance and damping applications. The A Series range is described in Section 1, starting on page 7.

AP Series Piston Accumulators

The AP Series is a range of high performance accumulators designed for demanding applications such as die-casting and plastic injection moulding, where high flow rates and piston speeds up to 8m/s are routinely demanded. AP Series accumulators are described in Section 2, starting on page 17.

When selecting a piston accumulator, factors to be considered should include the following:

- appropriate certification for country of final destination
- maximum working pressure
- fluid capacity
- gas capacity
- piston speed, port type and size
- mounting space and orientation

In addition, the type of gas valve and its connection and the requirement for a charging and gauging kit should also be considered. In certain applications, the use of a safety shut-off valve or 'safety block' is mandatory, and a suitable valve should be incorporated into the system design, as close as possible to the accumulator which it regulates. Parker offers a range of safety blocks for this purpose – see Catalogue no.1241.

Mounting

The wide variety of lengths and bore sizes available within Parker's piston accumulator range makes this design particularly suitable for applications where mounting space is critical. The same fluid capacity can be achieved from different configurations of bore and overall length, providing exceptional versatility for

the designer. While the optimum mounting orientation is vertical, angled and horizontal mountings are permissible if the hydraulic fluid is kept clean; high levels of contaminants in the fluid can result in uneven or accelerated seal wear.

Auxiliary Gas Bottles

To enhance the versatility of Parker's piston accumulator ranges, auxiliary gas bottles are available to provide a remote source of pre-charge pressure in situations where accumulator mounting space is restricted. The B and BP Series gas bottles featured in Sections 3 and 4 of this catalogue employ a similar threaded-end construction to the A and AP Series piston accumulators.

Gas Bottle Selection Guide

Series	Standard Approval	Max. Working Pressure	Gas Capacity litres	Bore Dia.	Interface	Page
B	CE	350	1.5-40	100 & 150mm 4 & 6in.	Metric & Inch	27
BP	CE	350	8.5-322	180-360mm	Metric	35

In addition, gas bottles with a forged-end construction are also available and may provide a cost-effective solution in certain applications – please ask your local Parker sales office for details.

Optional Features

The accumulators and gas bottles featured on the following pages are metric-mounted products which meet European CE approvals; A and B Series accumulators and gas bottles are also available with inch-series mountings. On request, Parker can also supply a range of non-standard products – please contact the factory for further details.

Piston Position/Precharge Monitoring – various designs are available to suit different applications. Our engineers will be pleased to provide further information.

Other approvals such as TÜV, DRIRE, ISPEL etc. are available for use where local or non-European Union approvals are demanded.

Special designs – for applications where a standard accumulator or gas bottle is not suitable, our engineers will be pleased to discuss custom designs to suit your application.

Accessories – safety fuses, mounting brackets, charging and gauging kits etc.

A Series Piston Accumulators

- Heavy duty construction for industrial and mobile applications
- CE approved to European Standard 97/23/EC
- 250 and 350 bar working pressures
- Oil volumes from 0.1 to 38 litres
- Suitable for piston speeds up to 4m/s
- Wide range of port and seal options
- Metric and inch mounting styles



Contents	
250 bar piston accumulators	10
350 bar piston accumulators	12

A Series Piston Accumulators

Parker's A Series accumulators are a compact, robust design which has been proven in thousands of applications worldwide. Designed for general purpose applications where piston speeds and flow rates are relatively low, A Series accumulators are ideal for applications such as power units, pressure maintenance and damping applications. A wide range of bore/stroke combinations enables the right volume to be selected in a size that will optimise the use of available space, while metric and inch mountings and a choice of port styles simplify connection.

250 and 350 Bar Pressure Ranges

A Series industrial accumulators are available in two different pressure ratings, to suit maximum working pressures of 250 and 350 bar. The same premium quality design and technical features guarantee optimum performance and service life from every model, while differing wall thicknesses to suit 250 or 350 bar working pressures allow the designer to specify precisely the right performance envelope for the application.

Specification

Max. working pressures	250 and 350 bar
Working temp. range	shell: -10 to +150°C (CE approved) seals: see pages 11 and 13
Fluid volumes	0.1–38 litres
Bore sizes	50–150mm (nominal)
Max. piston speed	4m/s
Port style	BSPP (standard – others on request)
Gas valve	350 bar rated cored type
Approval	CE (standard – others on request)

Materials

- Shell – high strength steel
- End caps – steel
- Pistons – lightweight aluminium alloy
- Piston and cap end seals – NBR (standard): other compounds to suit application
- Piston seal backup washers – PTFE
- Piston bearing rings – PTFE
- Gas valve assembly – stainless steel
- Gas valve protector – steel
- Paint finish – black primer (standard – others on request)

Actual Bore Sizes and Maximum Flow Rates

Model	Nominal Bore Dia. mm	Actual Bore Dia. mm	Max. Recommended Flow lpm
A2	50	51.4	380
A3	75	76.2	834
A4	100	102.4	1504
A6	150	146.9	3096

Custom Designs

For unique applications and hostile environments, different designs and materials can be supplied. Please contact our engineering department to discuss custom solutions to individual application requirements.

Available Options

A wide variety of options is available for A Series accumulators, including:

- Port styles and sizes
- Seal compounds
- Metric and inch mounting styles
- High flow gas ports for use with remote gas storage bottles
- Water service versions
- Gas valves
- Safety fuses
- Accumulator mounting systems
- Precharge/piston position sensors
- Certifications to suit different market requirements

Calculating Accumulator Size

Accurate calculation of accumulator size requires many factors to be considered – the working volume of oil, ambient and maximum operating temperatures, the working pressure range etc. In addition, correction factors must be applied to allow for temperature compensation between the ambient and gas temperatures, and the consequent effect on precharge pressure in the accumulator. Where the working cycle is sufficiently rapid that no heat transfer takes place, the process is termed *adiabatic*. Conversely, where the process takes place at a constant temperature, it is termed *isothermal*. Calculations and sizing charts which enable the designer to compensate for these differing conditions are shown on page 43.

Filtration

For maximum component life, the system should be protected from contamination by effective filtration. Fluid cleanliness should be in accordance with ISO 4406. The quality of filters should be in accordance with the appropriate ISO standards.

The rating of the filter media depends on the system components and the application. The minimum required for hydraulic systems should be class 19/15 to ISO 4406, which equates to 25µ (β10 ≥ 75) to ISO 4572.

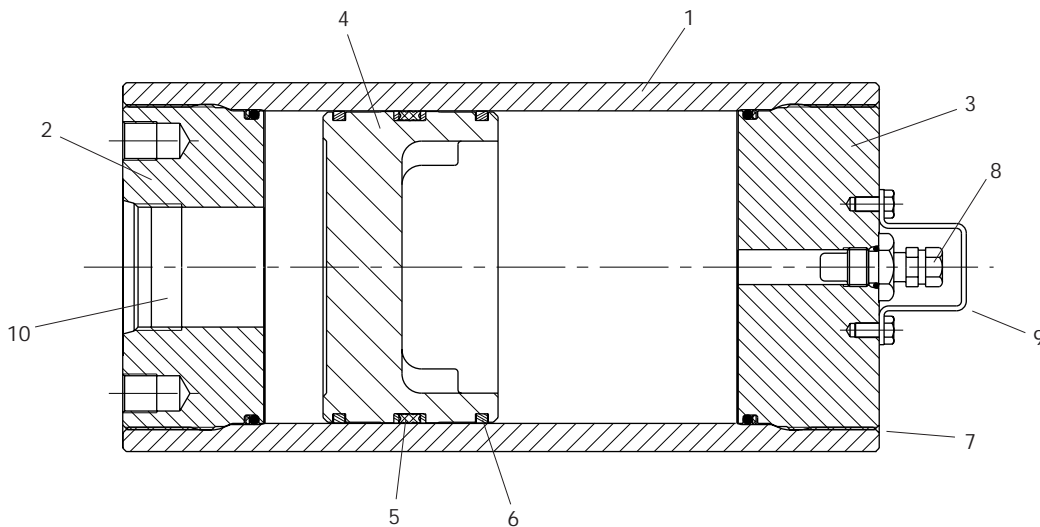

1, 2 & 3 Shell and Caps

Effective heat dissipation is vital for long seal life. Compact, rugged steel shell and end caps allow heat to dissipate efficiently, while the bore of the accumulator is micro-finished to maximise seal life. Downtime is minimised by the use of threaded caps to simplify maintenance of the accumulator, permitting quick and easy installation of seals.

4 Piston

Rapid response in high cycling applications is assured by Parker's lightweight piston design. The dished profile of the aluminium piston gives extra gas capacity while retaining stability in the bore, and permits a greater usable volume of fluid. Position sensors, available as an optional feature, register the position of the piston, enabling the condition of the accumulator's precharge to be monitored.

5 Piston Sealing

Long service intervals demand total separation of oil and gas, even under the most severe operating conditions. Parker's A Series accumulators feature a wide piston seal assembly comprising a unique five-bladed V-profile O-ring with back-up washers, which eliminates seal roll-over even in high speed applications.

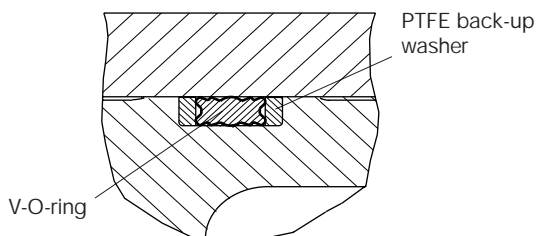

The V-O-ring holds full pressure throughout long idle periods between cycles, providing dependable, full pressure storage of hydraulic energy. It ensures safe, reliable absorption of pressure peaks and helps to prevent the catastrophic failure modes associated with bladder and diaphragm accumulator designs.

6 PTFE Bearing Rings

To reduce wear and extend service life, carbon-filled PTFE bearing rings are fitted, eliminating metal-to-metal contact between the piston and bore.

7 Safety Bleed Grooves

A bleed groove in the gas cap progressively releases unrelieved gas pressure in the accumulator as the gas cap is unscrewed. **Note:** to avoid the risk of damage or injury, an accumulator must always be discharged before disassembly.

8 Gas Valve

To avoid the risk of damage or injury, an accumulator must be discharged before disassembling. For added safety, the gas valves fitted by Parker vent progressively as they are unscrewed. A robust, cored-type gas valve rated at 350 bar is fitted as standard to all A Series piston accumulators. A mechanically opened and closed poppet-type gas valve cartridge, also rated at 350 bar, is available as an option.

9 Gas Valve Protector

To prevent accidental – and potentially hazardous – damage to the gas valve, the steel gas valve protector reduces the risk to the valve from external impact.

10 Ports

To provide the required flow rate and simplify system design, a wide range of port types and sizes is available. BSPP ports are fitted as standard; ISO, metric and SAE threaded and metric flanged ports to ISO 6162 are available to special order.

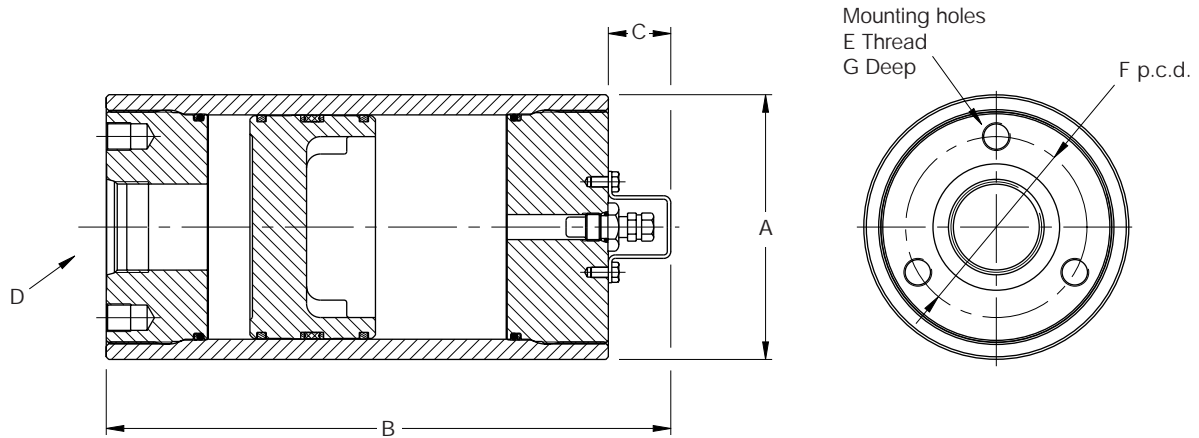

250 Bar A Series Piston Accumulator with CE Approval

250 Bar Models, Capacities and Dimensions

Model	Code <small>see page 16</small>	Bore Ø	Volume Litres	A	B	C	D BSPP	E ²	F	G	Weight kg
A2	0005	51.4	0.1	60.5	172	27 ¹	G ³ / ₄	-	-	-	1.8
	0010		0.15		211						2.0
	0015		0.25		250						2.5
	0029		0.5		360						3.0
	0058		1.0		590						4.4
A3	0029	76.2	0.5	90.4	29 ¹	G1	M10	60	15	9.0	
	0058		1.0							260	11
	0090		1.5							364	13
	0116		2.0							481	14
A4	0183	102.4	3.0	121	29 ¹	G1	M12	82	18	16	
	0058		1.0							295	15
	0116		2.0							411	18
	0231		3.8							640	23
	0347		5.7							872	29
A6	0578	146.9	9.5	175	29 ¹	G1 ¹ / ₂	M12	110	18	41	
	0231		3.8							442	35
	0347		5.7							554	42
	0578		9.5							778	54
	0924		15							1113	73
	1155		19							1337	85
	1733		28.5							1896	112
2310	38	2454	147								

¹ Where the optional poppet-type gas valve is fitted (see page 14), dimension C should be increased by 13mm.

² A Series 250 bar piston accumulators are supplied as standard with the metric threaded mounting holes shown in the table. They are also available with inch pattern mounting holes, indicated by the Design Number in the model code – see page 16.

Hydraulic and Gas Ports

The ports shown above are supplied as standard at the fluid ends of A Series 250 bar accumulators, and at the gas ends of these accumulators when ordered for use with gas bottles. A range of optional threaded and flanged ports is also available, as shown in the tables opposite. These are specified by

adding the relevant code to the accumulator model number – see page 16. Note that, where the required port is the standard BSPP size for the accumulator model chosen, the port fields in the order code should be left blank.

All dimensions are in millimetres unless otherwise stated.

Optional Threaded Ports

BSPP ¹			Metric to DIN 3852-1			Metric to ISO 6149-1			SAE Thread		
Thread Size	From Model	Code	Thread Size	From Model	Code	Thread Size	From Model	Code	Thread Size	From Model	Code
G ³ / ₄	A2	RC	M14	A2	GA	M14	A2	YA	#5	A2	TA
G1	A3	RD	M18	A2	GB	M18	A2	YB	#6	A2	TB
G1 ¹ / ₄	A3	RE	M22	A2	GC	M22	A2	YC	#8	A2	TC
G1 ¹ / ₂	A4	RF	M27	A2	GD	M27	A2	YD	#10	A2	TI
G2	A4	RG	M33	A3	GE	M33	A3	YE	#12	A2	TD
-	-	-	M42	A3	GF	M42	A3	YF	#16	A3	TE
-	-	-	-	-	-	-	-	-	#20	A3	TF
-	-	-	-	-	-	-	-	-	#24	A4	TG

¹ Where the required port is the standard BSPP size for the accumulator bore diameter chosen (see dimension D, page 10), the port fields in the order code should be left blank – see page 16.

Optional Flanged Ports

CE-approved A Series accumulators are available with metric flange ports to ISO 6162, as shown in the table. A Series accumulators are also available with inch pattern flange ports to ISO 6162 – please consult the factory for details.

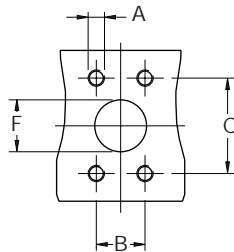

Flange Ports to ISO 6162						
Flange Size	From Model	A	B ±0.25	C ±0.25	F	Code
DN13	A3	M8	17.5	38.1	13	MT
DN19	A3	M10	22.3	47.6	19	MU
DN25	A3	M10	26.2	52.4	25	MV
DN32	A3	M10	30.2	58.7	32	MW
DN38	A4	M16	35.7	69.9	38	MJ
DN51	A4	M12	42.9	77.8	51	ML

Operating Temperatures and Fluid Media

A Series 250 bar piston accumulators are fitted as standard with nitrile (NBR) seals. A range of alternative seal materials is available for use at higher or lower temperatures, or with synthetic or high water content fluids, as shown in the table. Other seals are also available for use in exceptional conditions – please consult the factory with details of the application. The shells of Parker's A series accumulators are CE approved for operation at temperatures between -10°C and +150°C.

Seal Type	Code	Fluid Medium	Temperature Range
Nitrile (NBR)	K	General purpose, petroleum-based fluids	-30°C to +75°C
Fluorocarbon Elastomer (FPM)	E	High temperature and/or synthetic fluids	-25°C to +120°C
Ethylene Propylene (EPR)	D	Phosphate-esters	-40°C to +120°C
Hydrogenated Nitrile (HNBR)	H	Most oil-based and biodegradable fluids	-40°C to +160°C
Carboxilated Nitrile (XNBR)	J	Water glycol, high water content fluids	-30°C to +75°C
Low Temperature Nitrile (NBR)	Q	General purpose fluids at low temperatures	-45°C to +70°C

Water Service

A Series piston accumulators are available for use with water as the fluid medium. Modifications include plating of all working surfaces. Please consult the factory for details.

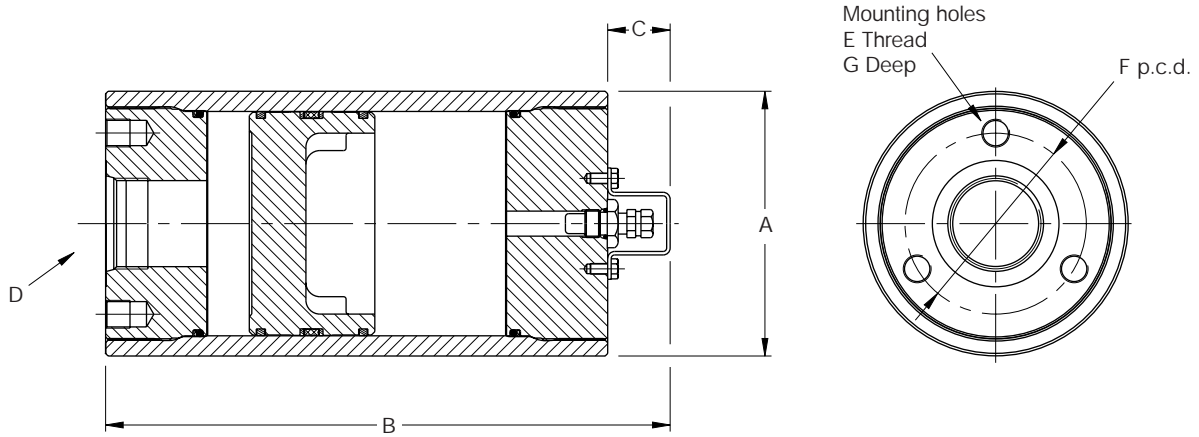

350 Bar A Series Piston Accumulator with CE Approval

350 Bar Models, Capacities and Dimensions

Model	Code <small>See page 16</small>	Bore Ø	Volume Litres	A	B	C	D BSPP	E ²	F	G	Weight kg
A2	0005	51.4	0.1	64	172	27 ¹	G ³ / ₄	-	-	-	2.7
	0010		0.15		211						3.0
	0015		0.25		250						4.3
	0029		0.5		360						6.2
	0058		1.0		590						8.4
A3	0029	76.2	0.5	96	260	29 ¹	G ³ / ₄	M10	60	15	10.2
	0058		1.0		364						13
	0090		1.5		481						15
	0116		2.0		573						20
A4	0183	102.4	3.0	127	814	29 ¹	G1	M12	82	18	18
	0058		1.0		306						22
	0116		2.0		422						30
	0231		3.8		651						38
	0347		5.7		883						54
A6	0578	146.9	9.5	180	1341	29 ¹	G1	M12	110	18	53
	0231		3.8		487						60
	0347		5.7		600						74
	0578		9.5		824						96
	0924		15		1159						110
	1155		19		1383						148
	1733		28.5		1941						183
2310	38	2500									

¹ Where the optional poppet-type gas valve is fitted (see page 14), dimension C should be increased by 13mm.

² A Series 350 bar piston accumulators are supplied as standard with the metric threaded mounting holes shown in the table. They are also available with inch pattern mounting holes, indicated by the Design Number in the model code – see page 16.

Hydraulic and Gas Ports

The ports shown above are supplied as standard at the fluid ends of A Series 350 bar accumulators, and at the gas ends of these accumulators when ordered for use with gas bottles. A range of optional threaded and flanged ports is also available, as shown in the tables opposite. These are specified by

adding the relevant code to the accumulator model number – see page 16. Note that, where the required port is the standard BSPP size for the accumulator model chosen, the port fields in the order code should be left blank.

All dimensions are in millimetres unless otherwise stated.

Optional Threaded Ports

BSPP ¹			Metric to DIN 3852-1			Metric to ISO 6149-1			SAE Thread		
Thread Size	From Model	Code	Thread Size	From Model	Code	Thread Size	From Model	Code	Thread Size	From Model	Code
G ³ / ₄	A2	RC	M14	A2	GA	M14	A2	YA	#5	A2	TA
G1	A3	RD	M18	A2	GB	M18	A2	YB	#6	A2	TB
G1 ¹ / ₄	A3	RE	M22	A2	GC	M22	A2	YC	#8	A2	TC
G1 ¹ / ₂	A4	RF	M27	A2	GD	M27	A2	YD	#10	A2	TI
G2	A4	RG	M33	A3	GE	M33	A3	YE	#12	A2	TD
-	-	-	M42	A3	GF	M42	A3	YF	#16	A3	TE
-	-	-	-	-	-	-	-	-	#20	A3	TF
-	-	-	-	-	-	-	-	-	#24	A4	TG

¹ Where the required port is the standard BSPP size for the accumulator bore diameter chosen (see dimension D, page 12), the port fields in the model code should be left blank – see page 16.

Optional Flanged Ports

CE-approved A Series accumulators are available with metric flange ports to ISO 6162, as shown in the table. A Series accumulators are also available with inch pattern flange ports to ISO 6162 – please consult the factory for details.

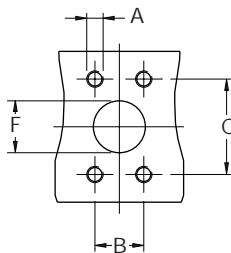

Flange Ports to ISO 6162						
Flange Size	From Model	A	B ±0.25	C ±0.25	F	Code
DN13	A3	M8	17.5	38.1	13	MT
DN19	A3	M10	22.3	47.6	19	MU
DN25	A3	M10	26.2	52.4	25	MV
DN32	A3	M10	30.2	58.7	32	MW
DN38	A4	M16	35.7	69.9	38	MJ
DN51	A4	M12	42.9	77.8	51	ML

Operating Temperatures and Fluid Media

A Series 350 bar piston accumulators are fitted as standard with nitrile (NBR) seals. A range of alternative seal materials is available for use at higher or lower temperatures, or with synthetic or high water content fluids, as shown in the table. Other seals are also available for use in exceptional conditions – please consult the factory with details of the application. The shells of Parker's A series accumulators are CE approved for operation at temperatures between -10°C and +150°C.

Seal Type	Code	Fluid Medium	Temperature Range
Nitrile (NBR)	K	General purpose, petroleum-based fluids	-30°C to +75°C
Fluorocarbon Elastomer (FPM)	E	High temperature and/or synthetic fluids	-25°C to +120°C
Ethylene Propylene (EPR)	D	Phosphate-esters	-40°C to +120°C
Hydrogenated Nitrile (HNBR)	H	Most oil-based and biodegradable fluids	-40°C to +160°C
Carboxylated Nitrile (XNBR)	J	Water glycol, high water content fluids	-30°C to +75°C
Low Temperature Nitrile (NBR)	Q	General purpose fluids at low temperatures	-45°C to +70°C

Water Service

A Series piston accumulators are available for use with water as the fluid medium. Modifications include plating of all working surfaces. Please consult the factory for details.

All dimensions are in millimetres unless otherwise stated.

Piston Accumulator Seal Kits

Seal kits are available for all A Series accumulator models. When ordering seal kits, please supply the complete model number from the identification plate and specify the fluid type and the temperature at which the accumulator is to be used.

Seal Kit Numbers

The seal kits listed contain items 5, 6, 7, 8, 9 and 11.

Parts List

- | | |
|------------------------------|------------------------------|
| 1 Shell | 8 O-ring |
| 2 Hydraulic cap | 9 O-ring back-up washer |
| 3 Gas cap | 10 Gas valve |
| 4 Piston | 11 Gas valve O-ring |
| 5 V-O-ring | 12 Gas valve protector |
| 6 V-O-ring back-up washers | 13 Gas valve protector screw |
| 7 PTFE bearing ring (piston) | |

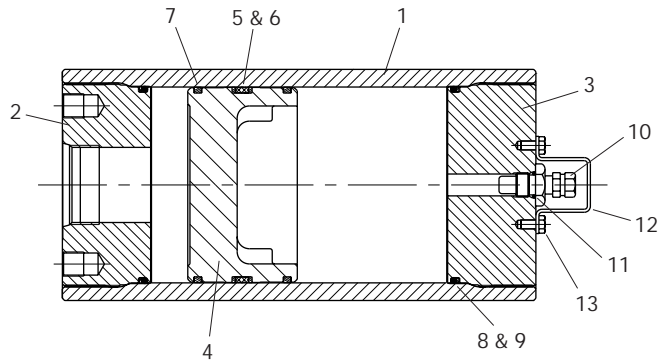

Model	Nitrile NBR	Fluorocarbon Elastomer FPM	Ethylene Propylene EPR	Hydrogenated Nitrile HNBR	Carboxylated Nitrile XNBR	Low Temp. Nitrile NBR
A2	RK0200K000	RK0200E000	RK0200D000	RK0200H000	RK0200J000	RK0200Q000
A3	RK0300K000	RK0300E000	RK0300D000	RK0300H000	RK0300J000	RK0300Q000
A4	RK0400K000	RK0400E000	RK0400D000	RK0400H000	RK0400J000	RK0400Q000
A6	RK0600K000	RK0600E000	RK0600D000	RK0600H000	RK0600J000	RK0600Q000

Gas Valves

The standard gas charging valve fitted to A Series 250 and 350 bar piston accumulators is a cored-type gas valve, rated at 350 bar. A mechanically opened and closed poppet-type gas valve cartridge, also rated at 350 bar, is available as an option.

Both types of charging valve may be used with the Charging and Gauging Kit illustrated opposite.

Safety Fuses

Safety fuses are available as a safety feature on accumulators and gas bottles to prevent over-pressurization of gas due to external heat or excess hydraulic pressure. They comprise a housing incorporating a disk which is calibrated to rupture at a pre-determined pressure, which should be specified by the customer at the time of ordering. Please contact the factory for further information.

Piston Position Sensors

Position sensors, available as an optional feature, register the position of the piston, enabling a wide range of conditions to be monitored. The position sensor illustrated is suitable for vertical mounting, and is one of several designs available to suit differing applications. In this design, non-contacting proximity sensors monitor the travel of a steel rod which bears against the gas side of the piston, indicating piston positions as specified by the customer. The resulting signals can be used to switch pumps on or off, or to operate control valves in a pre-set sequence. For alternative designs, please contact our Engineering Department with details of the application.

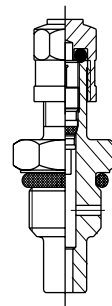

Standard Cored-Type Gas Valve

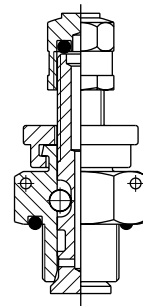

Optional Poppet-Type Gas Valve

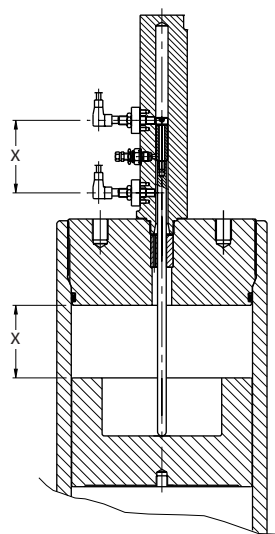

x = customer specified dimension

All dimensions are in millimetres unless otherwise stated.

'U' Bolts for Piston Accumulators

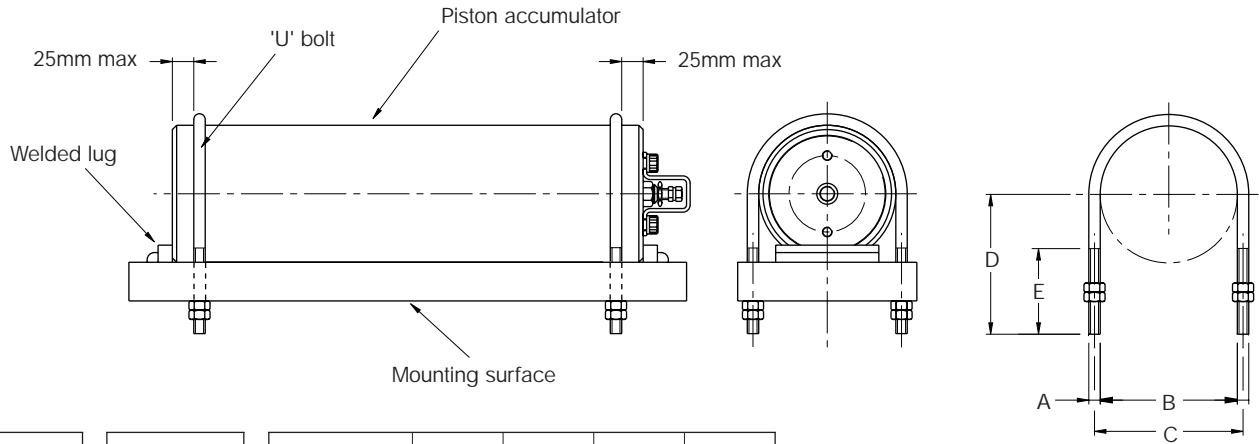

Model	Part No.	A	B	C	D	E
A2	PE1093-4	M6 x 1	62	68	70	45
A3	PE1093-1	M8 x 1.25	96	104	92	60
A4	PE1093-2	M12 x 1.75	128	140	114	76
A6	PE1093-3	M16 x 2	180	196	155	95

Note: 'U' bolts should never be mounted more than 25mm from the end of the accumulator to avoid deformation of the shell.

Charging and Gauging

The charging and gauging assemblies listed in the table are suitable for use with both the standard cored-type gas valve and the optional poppet type. Each kit contains a UCA assembly incorporating a gas valve, bleed valve and gas chuck, and a 3m long charging hose with standard nitrogen bottle fittings. The kit includes 25 bar and 250 bar pressure gauges, to permit easy monitoring of the gas precharge.

Territory	Gas Bottle Fitting	Part No.
UK	5/8 BSP (male)	UCA 02
France	W 21.7 x 1/14" (female)	UCA 04
Germany	W 24.32 x 1/14" (female)	UCA 01
Italy	W 21.7 x 1/14" (male)	UCA 05
US	0.960 x 1/14" (male)	UCA 03

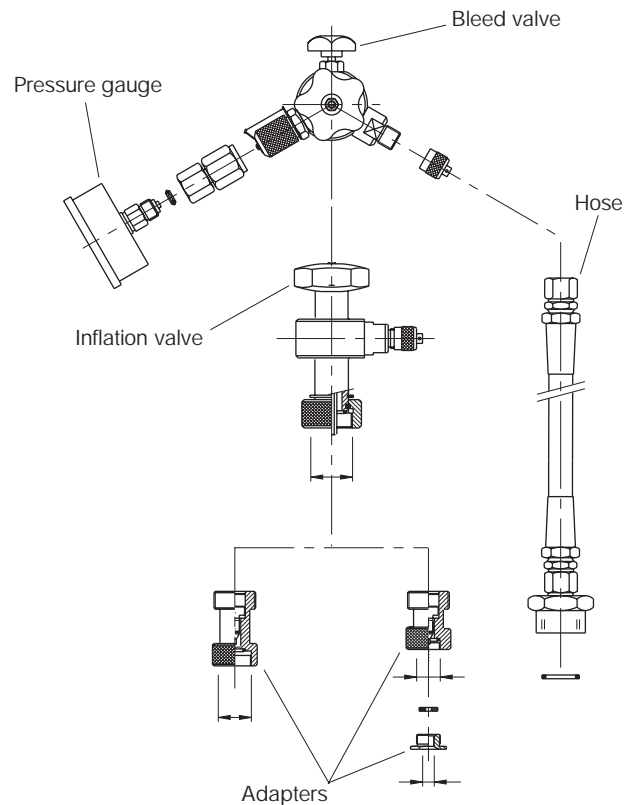

All dimensions are in millimetres unless otherwise stated.

Model Numbers

Each Parker accumulator is assigned a model number which represents the features selected. To develop a model number, identify the relevant characters from the table below and enter them in the sequence shown in the example.

Hydraulic and Gas Port Modifications

For accumulators with non-standard ports, specify special gas and/or hydraulic ports and use the appropriate port code from pages 11 or 13. A typical model number for an accumulator with ISO 6149 hydraulic and gas ports would be:

A	4	E	S	0183	L	2	K	YE/YE
---	---	---	---	------	---	---	---	-------

Feature	Description	Page	Symbol	Example												
				A	3	E	S	0090	L	2	K	--	/	--		
Product Type	A Series accumulator	7	A	●	●	●	●	●	●	●	●	●	●	●	●	
Model	A2 50mm bore	10-12	2	●	●	●	●	●	●	●	●	●	●	●	●	
	A3 75mm bore		3	●	●	●	●	●	●	●	●	●	●	●	●	
	A4 100mm bore		4	●	●	●	●	●	●	●	●	●	●	●	●	●
	A6 150mm bore		6	●	●	●	●	●	●	●	●	●	●	●	●	●
Approval Type	CE approved ¹	5	E	●	●	●	●	●	●	●	●	●	●	●	●	
Options	Cored-type gas valve (standard) ²	14	S	●	●	●	●	●	●	●	●	●	●	●	●	
	Cored-type gas valve + water service	13, 14	W	●	●	●	●	●	●	●	●	●	●	●	●	
	Cored-type gas valve + safety fuse	14	F	●	●	●	●	●	●	●	●	●	●	●	●	
	Cored-type gas valve + water service + safety fuse	13, 14	G	●	●	●	●	●	●	●	●	●	●	●	●	
	Poppet-type (MS) gas valve	14	M	●	●	●	●	●	●	●	●	●	●	●	●	
	Poppet-type gas valve + water service	13, 14	L	●	●	●	●	●	●	●	●	●	●	●	●	
	Poppet-type gas valve + safety fuse	14	P	●	●	●	●	●	●	●	●	●	●	●	●	
	Poppet-type gas valve + water service + safety fuse	13, 14	R	●	●	●	●	●	●	●	●	●	●	●	●	
Capacity (litres)	0.1 – A2 only	10, 12	0005	●	●	●	●	●	●	●	●	●	●	●	●	
	0.15 – A2 only		0010	●	●	●	●	●	●	●	●	●	●	●	●	
	0.25 – A2 only		0015	●	●	●	●	●	●	●	●	●	●	●	●	
	0.5 – A2 & A3		0029	●	●	●	●	●	●	●	●	●	●	●	●	
	1.0 – A2, A3, A4		0058	●	●	●	●	●	●	●	●	●	●	●	●	
	1.5 – A3 only		0090	●	●	●	●	●	●	●	●	●	●	●	●	
	2.0 – A3, A4		0116	●	●	●	●	●	●	●	●	●	●	●	●	
	3.0 – A3 only		0183	●	●	●	●	●	●	●	●	●	●	●	●	
	3.8 – A4, A6		0231	●	●	●	●	●	●	●	●	●	●	●	●	
	5.7 – A4, A6		0347	●	●	●	●	●	●	●	●	●	●	●	●	
	9.5 – A4, A6		0578	●	●	●	●	●	●	●	●	●	●	●	●	
	15 – A6 only		0924	●	●	●	●	●	●	●	●	●	●	●	●	
	19 – A6 only		1155	●	●	●	●	●	●	●	●	●	●	●	●	
28.5 – A6 only	1733	●	●	●	●	●	●	●	●	●	●	●	●			
38 – A6 only	2310	●	●	●	●	●	●	●	●	●	●	●	●			
Design Pressure ³	250 bar	8, 10	L	●	●	●	●	●	●	●	●	●	●	●	●	
	350 bar	8, 12	H	●	●	●	●	●	●	●	●	●	●	●	●	
Design Number	Metric mounting + BSPP ports (standard)	10-13	2	●	●	●	●	●	●	●	●	●	●	●	●	
	Inch mounting + SAE ports	10-13	1	●	●	●	●	●	●	●	●	●	●	●	●	
	Special ports	11, 13	3	●	●	●	●	●	●	●	●	●	●	●	●	
	Specials (Parker assigned design number)	-	###	●	●	●	●	●	●	●	●	●	●	●	●	
Seal Compound	Nitrile (NBR)	11, 13	K	●	●	●	●	●	●	●	●	●	●	●	●	
	Fluorocarbon Elastomer (FPM)	11, 13	E	●	●	●	●	●	●	●	●	●	●	●	●	
	Hydrogenated nitrile (HNBR)	11, 13	H	●	●	●	●	●	●	●	●	●	●	●	●	
	Ethylene Propylene (EPR)	11, 13	D	●	●	●	●	●	●	●	●	●	●	●	●	
	Carboxilated nitrile (XNBR)	11, 13	J	●	●	●	●	●	●	●	●	●	●	●	●	
	Low temperature nitrile	11, 13	Q	●	●	●	●	●	●	●	●	●	●	●	●	
	Special – please specify	11, 13	S	●	●	●	●	●	●	●	●	●	●	●	●	
Hydraulic port specification		See pages 10-13		●	●	●	●	●	●	●	●	●	●	●	●	
Gas port specification (no gas valve supplied)		See pages 10-13		●	●	●	●	●	●	●	●	●	●	●	●	

¹ Other approvals are available to order – please consult the factory.

² Where a gas port is specified, no gas valve will be supplied.

³ For other pressure ratings, please consult the factory.

AP Series *High Performance* Piston Accumulators

- Premium quality construction for demanding industrial applications
- CE approved to European Standard 97/23/EC
- 250 and 350 bar working pressures
- Oil volumes from 6.0 to 300 litres
- High performance sealing systems for piston speeds up to 8m/s
- Flow rates up to 45,000 lpm
- High flow ports for rapid cycling performance



Contents

250 bar piston accumulators	20
350 bar piston accumulators	22

AP Series Piston Accumulators

Parker's AP Series accumulators are a premium specification product designed for use in high performance applications such as die casting and plastic injection moulding, where large volumes of fluid have to be displaced at high speed. Special multi-element sealing systems have been developed to combine good servo application and load holding properties with the wear characteristics required to withstand continuous use at piston speeds of up to 8m/s.

A wide range of bore/stroke combinations enables an accumulator with the required volume to be selected in a size that will optimise the use of available space, while metric mountings and a choice of port styles simplify connection. Parker offers a full range of clamps to provide secure mounting.

250 and 350 Bar Pressure Ranges

AP Series industrial accumulators are available in two different pressure ratings, to suit maximum working pressures of 250 and 350 bar. The same premium quality design and technical features guarantee optimum performance and service life from every AP Series accumulator model, while differing wall thicknesses allow the designer to specify precisely the right performance envelope for the application.

Specifications –

Max. working pressures	250 and 350 bar*
Working temp. range	-10 to +80°C (to +150°C on request)
Fluid volumes	6.0 – 300 litres
Bore sizes	180, 250 and 360mm
Max. piston speed	8m/s
Port style	BSP (standard – others on request)
Seal type	multi-element oil and gas seals with twin low friction bearing rings
Gas valve	350 bar rated poppet type
Approval	CE (standard – others on request)

* For operation at temperatures above 80°C, please consult the factory.

Materials

- Shell – high strength steel
- End caps – steel
- Pistons – lightweight aluminium alloy
- Cap end seals – NBR (standard): other compounds to suit application
- Piston bearing rings – filled PTFE
- Piston seals – filled PTFE (standard): other compounds to suit application
- Gas valve assembly – stainless steel
- Gas valve protector – steel
- Paint finish – black primer, suitable for epoxy paint finishes (standard) – other finishes on request

Maximum Flow Rates

Model	Bore Dia. mm	Max. Recommended Flow lpm
AP180	180	12,000
AP250	250	23,000
AP360	360	45,000

Custom Designs

For unique applications and hostile environments, different designs and materials can be supplied. Please contact our engineering department to discuss custom solutions to individual application requirements.

Available Options

A wide variety of options is available for AP Series accumulators, including:

- Port styles and sizes
- Seal compounds
- High flow gas ports for use with remote gas storage bottles
- Water service versions
- Safety fuses
- Mounting systems
- Precharge/piston position sensors
- Certifications to suit different market requirements

Calculating Accumulator Size

Accurate calculation of accumulator size requires many factors to be considered – the working volume of oil, ambient and maximum operating temperatures, the working pressure range etc. In addition, correction factors must be applied to allow for temperature compensation between the ambient and gas temperatures, and the consequent effect on precharge pressure in the accumulator. Where the working cycle is sufficiently rapid that no heat transfer takes place, the process is termed *adiabatic*. Conversely, where the process takes place at a constant temperature, it is termed *isothermal*. Calculations which enable the designer to compensate for these differing conditions are shown on page 43.

Filtration

For maximum component life, the system should be protected from contamination by effective filtration. Fluid cleanliness should be in accordance with ISO 4406. The quality of filters should be in accordance with the appropriate ISO standards.

The rating of the filter media depends on the system components and the application. The minimum required for hydraulic systems should be class 19/15 to ISO 4406, which equates to 25µ (β10 ≥ 75) to ISO 4572.

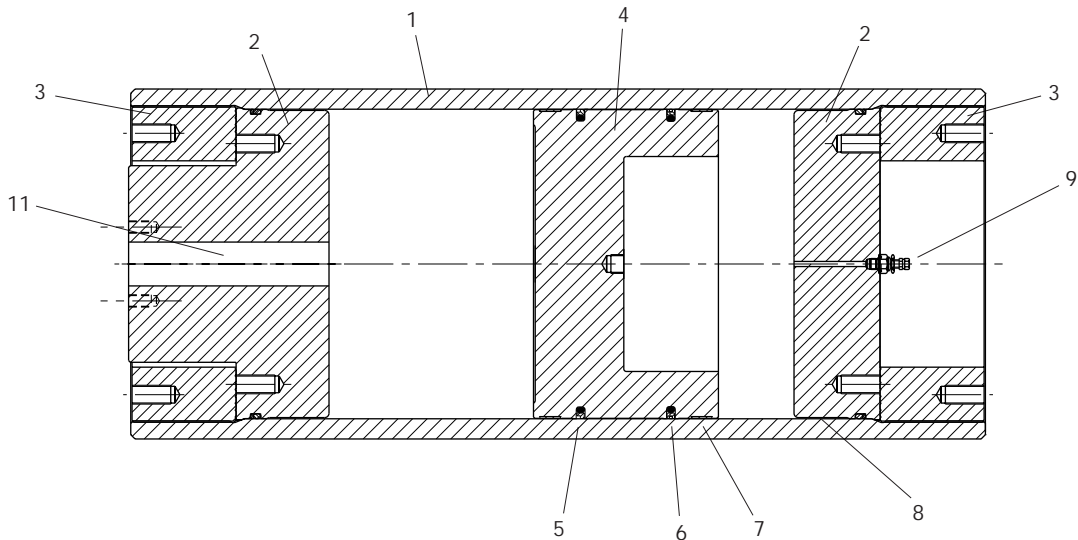

360mm Bore AP Series Accumulator with Flange Port
See Page 20 for cutaway view of 180/250mm bore models

1, 2 & 3 Shell and Caps

For maximum seal life, heat generated within the accumulator during rapid cycling must be dissipated quickly and efficiently. Compact, rugged steel shell and end caps permit rapid heat dissipation, while the bore of the accumulator is micro-finished to maximise seal life.

180mm and 250mm bore accumulators feature threaded caps to minimize downtime and simplify maintenance of the accumulator, permitting quick and easy installation of seals. 360mm bore units (illustrated) use a screwed ring (3) to retain the gas and oil caps, reducing the mass of parts handled during maintenance and providing additional protection for the gas valve.

4 Piston

Rapid response in high cycling applications is assured by Parker's lightweight piston design. The dished profile of the aluminium alloy piston gives extra gas capacity while retaining stability in the bore, and permits a greater usable volume of fluid.

5 & 6 Piston Sealing

Rapid cycling, with piston speeds up to 8m/s, places extreme demands on piston seals. Parker's AP Series accumulators employ seals with different performance characteristics for the oil and gas sides of the piston, selected to suit the differing operating conditions encountered.

The AP Series multi-element sealing system holds full pressure throughout long idle periods between cycles, providing dependable, full pressure storage of hydraulic energy. It ensures safe, reliable absorption of pressure peaks and helps to prevent the catastrophic failure modes associated with bladder accumulator designs.

7 PTFE Bearing Rings

To reduce wear and extend service life, filled PTFE bearing rings are fitted, eliminating metal-to-metal contact between the piston and bore, and protecting the piston seals from fluid-borne contaminants. Their low coefficient of friction minimizes heat build-up within the piston and shell.

8 Safety Bleed Groove

A bleed groove in the gas cap progressively releases unrelieved gas pressure in the accumulator as the gas cap is unscrewed. **Note:** to avoid the risk of damage or injury, an accumulator must always be discharged before disassembly.

9 Gas Valve

All AP Series piston accumulators are fitted as standard with a robust, mechanically opened/closed poppet-type gas valve rated at 350 bar. To avoid the risk of damage or injury, an accumulator must be discharged before disassembling but, for added safety, the gas valve vents progressively as it is unscrewed.

10 Gas Valve Protector

To prevent accidental – and potentially hazardous – damage to the gas valve, 180mm and 250mm bore AP Series accumulators are fitted with a steel gas valve protector. The gas valve on 360mm bore models (illustrated) is recessed within the shell to reduce the risk to the valve from external impact.

11 Ports

To provide the required flow rate and simplify system design, a range of port types and sizes is available. BSPP ports are fitted as standard; metric flanged ports to ISO 6162 and ISO 6164 are available as an option.

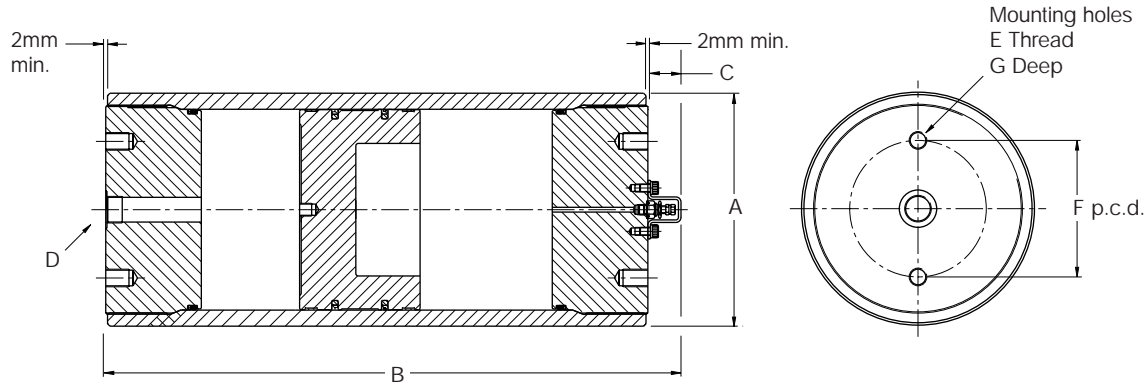

250 Bar AP Series, 180mm and 250mm Bore with CE Approval

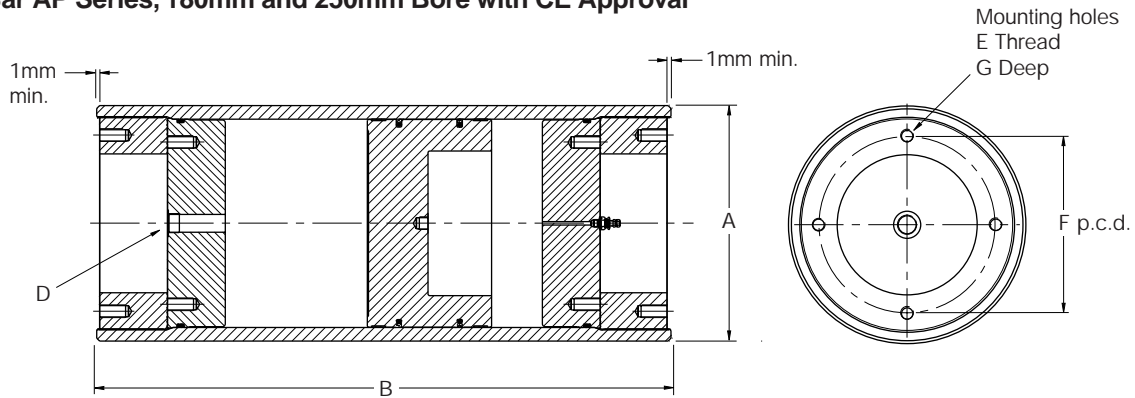

250 Bar AP Series, 360mm Bore with CE Approval

250 Bar Models, Capacities and Dimensions

Model	Code <small>See page 26</small>	Bore Ø	Volume Litres	A	B	C	D BSPP	E	F	G	Weight kg
AP180	006	180	6	207.0	591	42	G1½	M16 x 2	140	20	83
	008		8		669						88
	010		10		748						93
	015		15		944						106
	020		20		1141						118
	025		25		1337						131
	030		30		1534						143
	040		40		1927						168
	050		50		2320						193
	060		60		2713						218
080	80	3499	268								
AP250	030	250	30	290.0	1041	42	G1½	M22 x 2.5	170	30	245
	040		40		1245						271
	050		50		1449						298
	060		60		1652						325
	080		80		2060						379
	100		100		2467						432
150	150	3486	566								
AP360	100	360	100	407.0	1657 ¹	N/A	G1½	M22 x 2.5	304	45	639
	150		150		2149 ¹						742
	200		200		2640 ¹						845
	250		250		3131 ¹						948
	300		300		3622 ¹						1051

All dimensions are in millimetres unless otherwise stated.

¹ Flange mounting surface on AP360 Series extends 2mm beyond shell.

Hydraulic and Gas Ports

The BSPP ports shown are supplied as standard at the fluid ends of AP Series 250 bar accumulators, and at the gas ends of these accumulators when ordered for use with gas bottles. A range of optional threaded and flanged ports is also available, as shown below. All ports are specified by adding the relevant code to the accumulator model number – see page 26.

BSPP Threaded Ports

Thread Size	From Model	Code
G1	All models	RD
G1 ¹ / ₄		RE
G1 ¹ / ₂ (standard)		RF
G2		RG

Optional Flanged Ports

Bore Ø	ISO Port Style	DN10	DN13	DN19	DN25	DN32	DN38	DN51	DN56	DN63	DN70	DN80
180	ISO 6162											
	ISO 6164											
250	ISO 6162											
	ISO 6164											
360	ISO 6162											
	ISO 6164											

ISO 6162 Flanged Port Dimensions

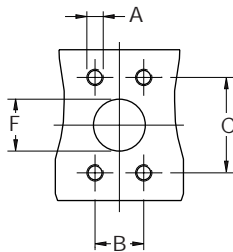

ISO 6164 Flanged Port Dimensions

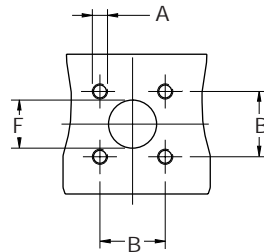

Flange Ports to ISO 6162 – 400 Bar Series					
Flange Size	A	B ±0.25	C ±0.25	F	Code
DN13	M8 x 1.25	18.2	40.5	13	ME
DN19	M10 x 1.5	23.8	50.8	19	MF
DN25	M12 x 1.75	27.8	57.2	25	MG
DN32	M12 x 1.75	31.8	66.6	32	MH
DN38	M16 x 2	36.5	79.3	38	MP
DN51	M20 x 2.5	44.5	96.8	51	MQ

Operating Temperatures and Fluid Media

Standard and optional seal combinations for AP Series accumulators are shown below. Other seals are also available for use in exceptional conditions – please consult the factory with details of the application. The shells of Parker's AP Series accumulators are CE approved for operation at temperatures between -10°C and +150°C.

Seal Type	Code	Fluid Medium	Seal Temperature Range
Nitrile (NBR) and filled PTFE	K	General purpose, petroleum-based fluids	-30°C to +75°C
Fluorocarbon elastomer (FPM) and filled PTFE	E	High temperature and/or synthetic fluids	-25°C to +150°C
Ethylene Propylene (EPR) and filled PTFE	D	Phosphate-esters	-25°C to +120°C
Hydrogenated nitrile (HNBR) and filled PTFE	H	Most oil-based and biodegradable fluids	-30°C to +130°C
Nitrile (NBR) and filled PTFE	J	Water glycol, high water content fluids	-30°C to +75°C
Low temperature nitrile (NBR) and filled PTFE	Q	General purpose fluids at low temperatures	-45°C to +70°C

Flange Ports to ISO 6164 – 400 Bar Series				
Flange Size	A	B ±0.25	F +0.0 -1.5	Code
DN10	M6 x 1	24.7	10.0	SD
DN13	M8 x 1.25	29.7	13.0	SE
DN19	M8 x 1.25	35.4	19.0	SF
DN25	M10 x 1.5	43.8	25.0	SG
DN32	M12 x 1.75	51.6	32.0	SH
DN38	M16 x 2	60.1	38.0	SP
DN51	M16 x 2	69.3	51.0	SQ
DN56	M20 x 2.5	83.4	56.0	SX
DN63	M24 x 3	102.5	63.0	SR
DN70	M24 x 3	113.1	70.0	SY
DN80	M30 x 3.5	123.7	80.0	SZ

Water Service

AP Series piston accumulators are available for use with water as the fluid medium. Modifications include plating of all working surfaces. Please consult the factory for details.

All dimensions are in millimetres unless otherwise stated.

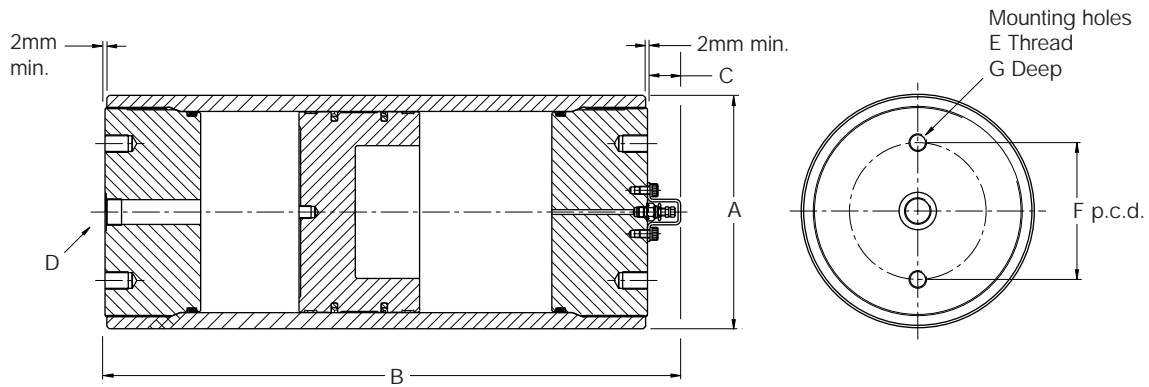

350 Bar AP Series, 180mm and 250mm Bore with CE Approval

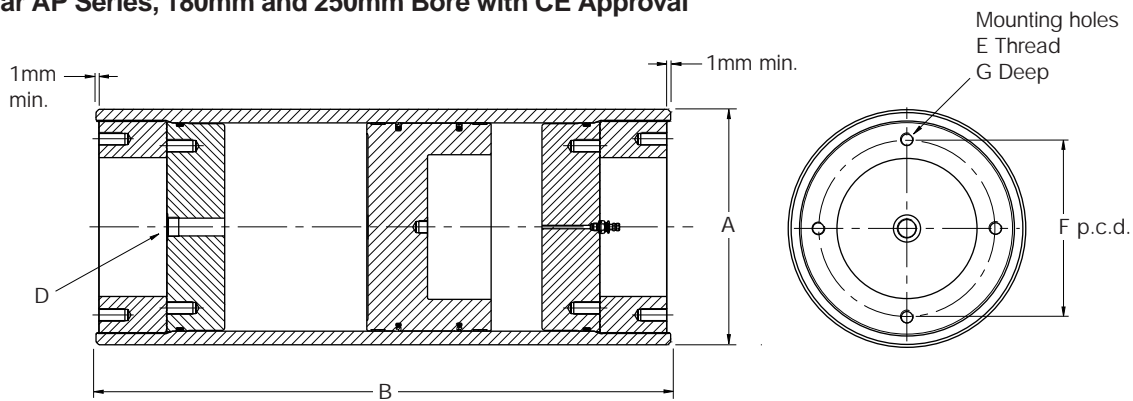

350 Bar AP Series, 360mm Bore with CE Approval

350 Bar Models, Capacities and Dimensions

Model	Code See page 26	Bore Ø	Volume Litres	A	B	C	D BSPP	E	F	G	Weight kg
AP180	006	180	6	220.0	591	42	G1½	M16 x 2	140	20	102
	008		8		669						109
	010		10		748						117
	015		15		944						136
	020		20		1141						155
	025		25		1337						175
	030		30		1534						194
	040		40		1927						232
	050		50		2320						270
	060		60		2713						309
080	80	3499	385								
AP250	030	250	30	310.0	1041	42	G1½	M22 x 2.5	170	30	317
	040		40		1245						359
	050		50		1449						401
	060		60		1652						442
	080		80		2060						526
	100		100		2467						609
	150		150		3486						817
AP360	100	360	100	436.0	1657 ¹	N/A	G1½	M22 x 2.5	304	45	903
	150		150		2149 ¹						1083
	200		200		2640 ¹						1264
	250		250		3131 ¹						1445
	300		300		3622 ¹						1626

All dimensions are in millimetres unless otherwise stated.

¹ Flange mounting surface on AP360 Series extends 2mm beyond shell.

Hydraulic and Gas Ports

The BSPP ports shown are supplied as standard at the fluid ends of AP Series 350 bar accumulators, and at the gas ends of these accumulators when ordered for use with gas bottles. A range of optional threaded and flanged ports is also available, as shown below. All ports are specified by adding the relevant code to the accumulator model number – see page 26.

BSPP Threaded Ports

Thread Size	From Model	Code
G1	All models	RD
G1 ¹ / ₄		RE
G1 ¹ / ₂ (standard)		RF
G2		RG

Optional Flanged Ports

Bore Ø	ISO Port Style	DN10	DN13	DN19	DN25	DN32	DN38	DN51	DN56	DN63	DN70	DN80
180	ISO 6162											
	ISO 6164											
250	ISO 6162											
	ISO 6164											
360	ISO 6162											
	ISO 6164											

ISO 6162 Flanged Port Dimensions

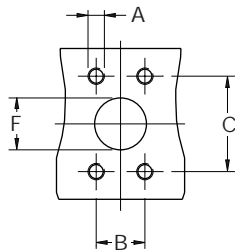

ISO 6164 Flanged Port Dimensions

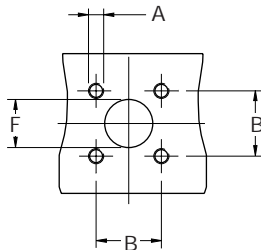

Flange Ports to ISO 6162 – 400 Bar Series					
Flange Size	A	B ±0.25	C ±0.25	F	Code
DN13	M8 x 1.25	18.2	40.5	13	ME
DN19	M10 x 1.5	23.8	50.8	19	MF
DN25	M12 x 1.75	27.8	57.2	25	MG
DN32	M12 x 1.75	31.8	66.6	32	MH
DN38	M16 x 2	36.5	79.3	38	MP
DN51	M20 x 2.5	44.5	96.8	51	MQ

Operating Temperatures and Fluid Media

Standard and optional seal combinations for AP Series accumulators are shown below. Other seals are also available for use in exceptional conditions – please consult the factory with details of the application. The shells of Parker's AP Series accumulators are CE approved for operation at temperatures between -10°C and +150°C.

Seal Type	Code	Fluid Medium	Seal Temperature Range
Nitrile (NBR) and filled PTFE	K	General purpose, petroleum-based fluids	-30°C to +75°C
Fluorocarbon elastomer (FPM) and filled PTFE	E	High temperature and/or synthetic fluids	-25°C to +150°C
Ethylene Propylene (EPR) and filled PTFE	D	Phosphate-esters	-25°C to +120°C
Hydrogenated nitrile (HNBR) and filled PTFE	H	Most oil-based and biodegradable fluids	-30°C to +130°C
Nitrile (NBR) and filled PTFE	J	Water glycol, high water content fluids	-30°C to +75°C
Low temperature nitrile (NBR) and filled PTFE	Q	General purpose fluids at low temperatures	-45°C to +70°C

Flange Ports to ISO 6164 – 400 Bar Series				
Flange Size	A	B ±0.25	F +0.0 -1.5	Code
DN10	M6 x 1	24.7	10.0	SD
DN13	M8 x 1.25	29.7	13.0	SE
DN19	M8 x 1.25	35.4	19.0	SF
DN25	M10 x 1.5	43.8	25.0	SG
DN32	M12 x 1.75	51.6	32.0	SH
DN38	M16 x 2	60.1	38.0	SP
DN51	M16 x 2	69.3	51.0	SQ
DN56	M20 x 2.5	83.4	56.0	SX
DN63	M24 x 3	102.5	63.0	SR
DN70	M24 x 3	113.1	70.0	SY
DN80	M30 x 3.5	123.7	80.0	SZ

Water Service

AP Series piston accumulators are available for use with water as the fluid medium. Modifications include plating of all working surfaces. Please consult the factory for details.

All dimensions are in millimetres unless otherwise stated.

Piston Accumulator Seal Kits

Seal kits are available for all AP Series accumulator models. When ordering seal kits, please supply the complete model number from the identification plate and specify the fluid type and the temperature at which the accumulator is to be used. Installation and maintenance are described in Bulletin 1240-M1.

The seal kits listed below contain a piston with the appropriate seals ready fitted, to minimize the risk of damage during assembly. Seal kits contain items 5, 6, 7, 8, 9, 10 and 12.

Parts List

- 1 Shell
- 2 Hydraulic cap
- 3 Gas cap
- 4 Retaining ring (AP360 only)
- 5 Piston
- 6 Piston oil seal assembly
- 7 Piston gas seal assembly
- 8 Piston bearing ring
- 9 Cap O-ring
- 10 Cap O-ring back-up washer
- 11 Gas valve
- 12 Gas valve O-ring
- 13 Gas valve protector (not AP360)
- 14 Gas valve protector screw (not AP360)

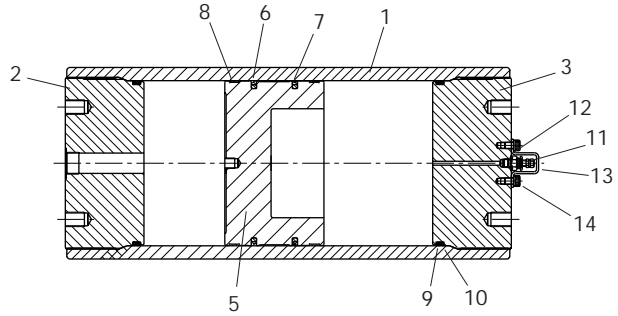

180mm and 250mm Bore Piston Accumulators

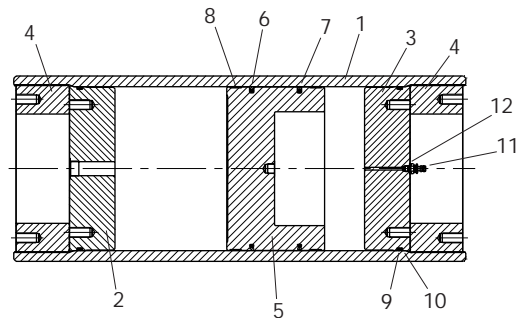

360mm Bore Piston Accumulator

Model	Seal Material + Filled PTFE					
	Nitrile NBR	Fluorocarbon Elastomer FPM	Ethylene Propylene EPR	Hydrogenated Nitrile HNBR	Nitrile (HWBF) NBR	Low Temp. Nitrile NBR
AP180	PK180APK	PK180APE	PK180APD	PK180APH	PK180APJ	PK180APQ
AP250	PK250APK	PK250APE	PK250APD	PK250APH	PK250APJ	PK250APQ
AP360	PK360APK	PK360APE	PK360APD	PK360APH	PK360APJ	PK360APQ

Gas Valves

The standard gas charging valve fitted to AP Series 250 and 350 bar piston accumulators is a mechanically opened and closed poppet-type gas valve cartridge, rated at 350 bar. This charging valve may be used with the Charging and Gauging Kit illustrated opposite.

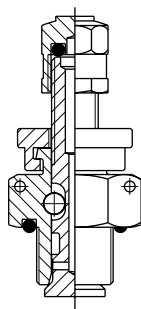

Safety Fuses

Safety fuses are available as a safety feature on accumulators and gas bottles to prevent over-pressurization of gas due to external heat or excess hydraulic pressure. They comprise a housing incorporating a disk which is calibrated to rupture at a pre-determined pressure, which should be specified by the customer at the time of ordering. Please contact the factory for further information.

Piston Position Sensor

Position sensors, available as an optional feature, register the position of the piston, enabling a wide range of conditions to be monitored. The position sensor illustrated is suitable for vertical mounting, and is one of several designs available to suit differing applications. In this design, non-contacting proximity sensors monitor the travel of a steel rod which bears against the gas side of the piston, indicating piston positions as specified by the customer. The resulting signals can be used to switch pumps on or off, or to operate control valves in a pre-set sequence. For alternative designs, please contact our Engineering Department with details of the application.

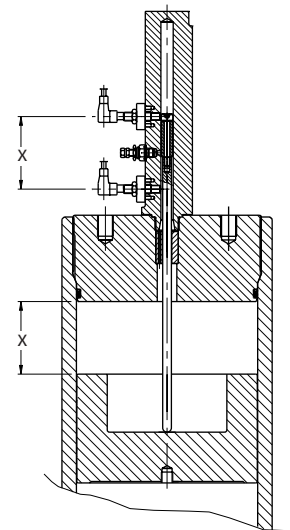

x = customer specified dimension

'U' Bolts for Piston Accumulators

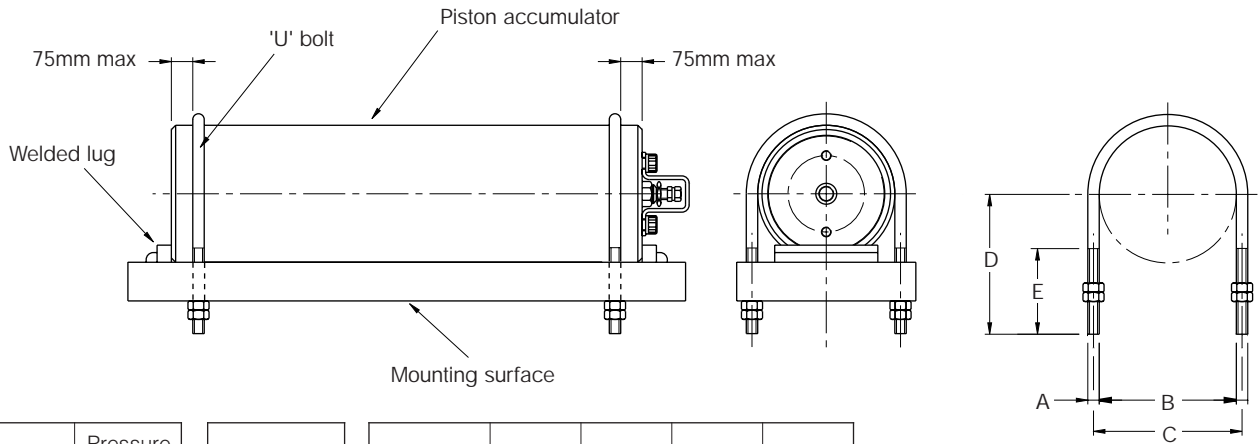

Model	Pressure Rating	Part No.	A	B	C	D	E
AP180	250	PE1093-5	M16 x 2	210	226	180	95
	350	PE1093-8		224	240	185	
AP250	250	PE1093-6	M20 x 2.5	286	306	240	115
	350	PE1093-9		312	332	256	
AP360	250	PE1093-10	M27 x 3	408	435	290	135
	350	PE1093-11		438	465	300	

Note: 'U' bolts should never be mounted more than 75mm from the end of the accumulator to avoid deformation of the shell.

Charging and Gauging

The charging and gauging assemblies listed in the table are suitable for use with the standard poppet-type gas valve. Each kit contains a UCA assembly incorporating a gas valve, bleed valve and gas chuck, and a 3m long charging hose with standard nitrogen bottle fittings. The kit includes 25 bar and 250 bar pressure gauges, to permit easy monitoring of the gas precharge.

Territory	Gas Bottle Fitting	Part No.
UK	5/8 BSP (male)	UCA 02
France	W 21.7 x 1/14" (female)	UCA 04
Germany	W 24.32 x 1/14" (female)	UCA 01
Italy	W 21.7 x 1/14" (male)	UCA 05
US	0.960 x 1/14" (male)	UCA 03

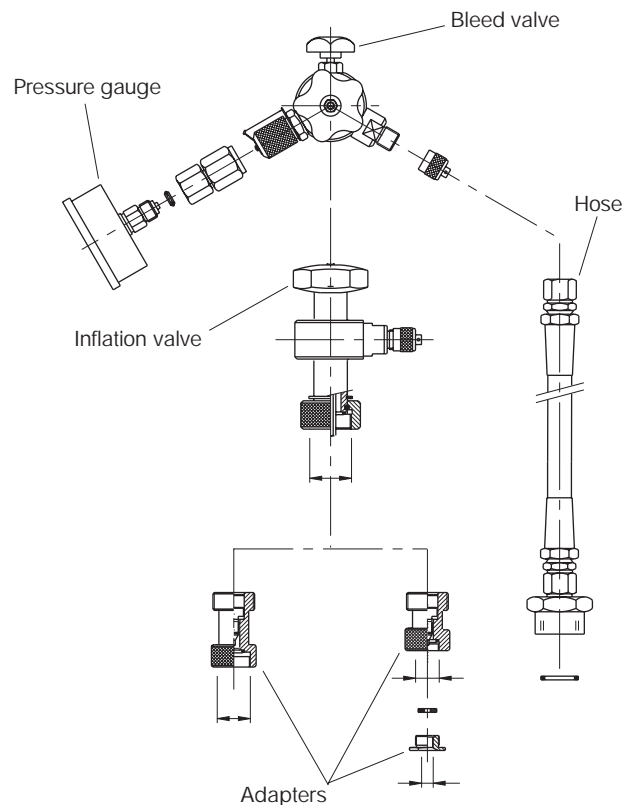

All dimensions are in millimetres unless otherwise stated.

Model Numbers

Each Parker accumulator is assigned a model number which represents the features selected. To develop a model number, identify the relevant characters from the table below and enter them in the sequence shown in the example.

Hydraulic and Gas Port Modifications

For accumulators with non-standard ports, specify special gas and/or hydraulic ports and use the appropriate port code from page 21 or 23. A typical model number for an accumulator with ISO 6164 hydraulic and gas ports would be:

AP	250	E	M	080	L	2	K	SF / SF
----	-----	---	---	-----	---	---	---	---------

Feature	Description	Page	Symbol	Example
Product Type	AP Series accumulator	17	AP	AP 250 E M 060 L 2 K -- / --
Model	180mm bore 250mm bore 360mm bore	20, 22	180 250 360	
Approval Type	CE approved ¹	5	E	
Options	Poppet-type (MS) gas valve (standard) ² Poppet-type gas valve + water service Poppet-type gas valve + safety fuse Poppet-type gas valve + water service + safety fuse	21, 23 21, 23 24 24	M L P R	
Capacity (litres)	6.0 – AP180 only 8.0 – AP180 only 10 – AP180 only 15 – AP180 only 20 – AP180 only 25 – AP180 only 30 – AP180 & AP250 40 – AP180 & AP250 50 – AP180 & AP250 60 – AP180 & AP250 80 – AP180 & AP250 100 – AP250 & AP360 150 – AP250 & AP360 200 – AP360 only 250 – AP360 only 300 – AP360 only	20, 22	006 008 010 015 020 025 030 040 050 060 080 100 150 200 250 300	
Design Pressure ³	250 bar 350 bar	20 22	L H	
Design Number	Standard Specials (Parker assigned design number)	20-23 –	2 ###	
Seal Compound	Nitrile (NBR) Fluorocarbon Elastomer (FPM) Ethylene Propylene (EPR) Nitrile (NBR) for high water-based fluids Low temperature nitrile Special – please specify	23 23 23 23 23 23	K E D H J Q	
Hydraulic port specification		Pages 20- 23		
Gas port specification (no gas valve supplied)		Pages 20- 23		

¹ Other approvals are available to order – please consult the factory.
² Where a gas port is specified, no gas valve will be supplied.
³ For other pressure ratings and for operating temperatures above 80°C, please consult the factory.

B Series Gas Bottles

- Heavy duty construction for industrial and mobile applications
- CE approved to European Standard 97/23/EC
- 250 and 350 bar working pressures
- Gas volumes from 1.5 to 40 litres
- Bore/length combinations to suit available space
- Wide range of port options
- Metric and inch mounting styles



Section 3

Contents

250 bar gas bottles	30
350 bar gas bottles	31

B Series Auxiliary Gas Bottles

Where space or constructional limitations prevent the installation of an accumulator large enough to deliver the flow rate required, a smaller accumulator may be used by connecting it to an auxiliary gas bottle which can be located elsewhere. This arrangement enables very high flow rates to be achieved while allowing the greater part of the accumulator's capacity to be given over to fluid. Because of the large precharge 'reservoir' provided by one or more auxiliary gas bottles, gas pressure is relatively constant over the full discharge cycle of the accumulator.

Where an accumulator is used with an auxiliary gas bottle, the travel of the accumulator piston must be carefully calculated to avoid impact with the accumulator caps. The accumulator gas port should be at least the same size as the hydraulic port of the accumulator.

Parker's B Series auxiliary gas bottles are a compact, robust design which has been proven in thousands of applications worldwide. A wide range of bore/length combinations enables the right volume to be selected in a size that will optimise the use of available space, while metric and inch mountings and a choice of port styles simplify connection.

250 and 350 Bar Pressure Ratings

B Series auxiliary gas bottles are available in two different pressure ratings, to suit maximum working pressures of 250 and 350 bar. The same premium quality design and technical features guarantee optimum performance and service life from every model, while differing wall thicknesses to suit 250 or 350 bar working pressures allow the designer to specify precisely the right performance envelope for the application.

Specification

Max. working pressures	250 and 350 bar
Working temp. range	shell: -10 to +150°C (CE approved) seals: see page 33
Fluid volumes	1.5 – 40 litres
Bore sizes	100mm and 150mm (nominal)
Port style	BSPP (standard – others on request)
Gas valve	350 bar rated cored type
Approval	CE (standard – others on request)

Materials

- Shell – high strength steel
- End caps – steel
- Seals – NBR (standard); other compounds to suit application
- Gas valve assembly – stainless steel
- Gas valve protector – steel
- Paint finish – black primer (standard – others on request)

Custom Designs

For unique applications and hostile environments, different designs and materials can be supplied. Please contact our engineering department to discuss custom solutions to individual application requirements.

Available Options

A wide variety of options is available for B Series Gas Bottles, including:

- Port styles and sizes
- O-ring seal compounds
- Metric and inch mounting styles
- Gas valves
- Safety fuses
- Mounting systems
- Certifications to suit different market requirements

Calculating Accumulator and Gas Bottle Size

Accurate calculation of accumulator and gas bottle size requires many factors to be considered – the working volume of oil, ambient and maximum operating temperatures, the working pressure range etc. In addition, correction factors must be applied to allow for temperature compensation between the ambient and gas temperatures, and the consequent effect on precharge pressure in the accumulator. Where the working cycle is sufficiently rapid that no heat transfer takes place, the process is termed *adiabatic*. Conversely, where the process takes place at a constant temperature, it is termed *isothermal*. Calculations and sizing charts which enable the designer to compensate for these differing conditions are shown on page 43.

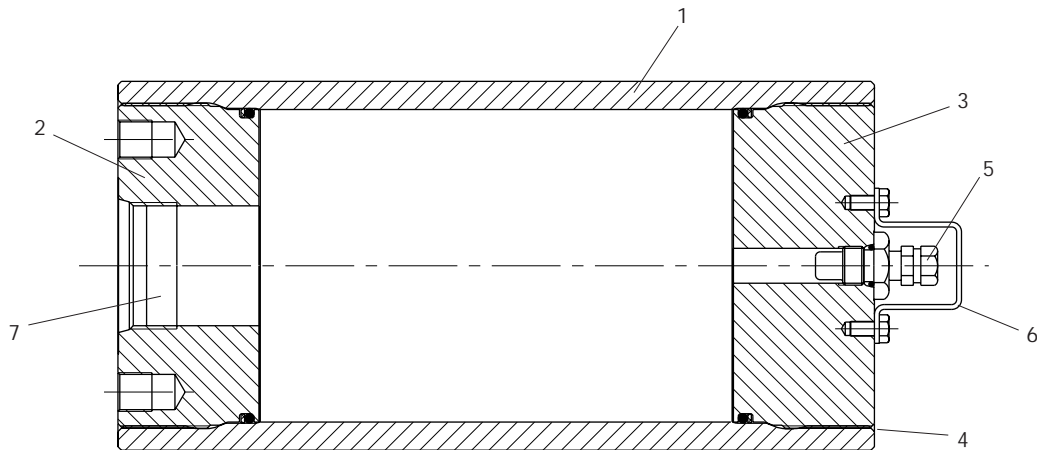

Features and Benefits

Parker's B Series auxiliary gas bottles share their construction with A Series accumulators, and many of the design features highlighted on page 9 apply also to these gas bottles.

Auxiliary gas bottles may be used singly to supplement/replace the gas storage capacity of the accumulator, or they may be manifolded together to provide a larger reservoir of gas pressure, if required. Where gas bottles are connected by a manifold, both ends of the shell are fitted with a cap of the type illustrated at 2 above. Where several bottles are connected by a manifold, only one bottle need be fitted with a gas valve for charging purposes.

1, 2 & 3 Shell and Caps

Compact, rugged steel shell and caps will survive even the toughest industrial environment, to provide reliable service year after year. In the unlikely event of maintenance being required, downtime is minimised by the use of threaded caps at both ends of the gas bottle, permitting quick and easy replacement of O-ring seals and back-up washers.

4 Safety Bleed Groove

A bleed groove in the gas cap progressively releases unrelieved pressure as the gas cap is unscrewed.

Note: to avoid the risk of damage or injury, a gas bottle must always be discharged before disassembly.

5 Gas Valve

To avoid the risk of damage or injury, a gas bottle must be discharged before disassembling. For added safety, the gas valves fitted by Parker vent progressively as they are unscrewed. A robust, cored-type gas valve rated at 350 bar is fitted as standard to all B Series auxiliary gas bottles. A mechanically opened and closed poppet-type gas valve cartridge, also rated at 350 bar, is available as an option.

6 Gas Valve Protector

To prevent accidental – and potentially hazardous – damage to the gas valve, the steel gas valve protector reduces the risk to the valve from external impact.

7 Ports

To provide the required gas transfer rate and simplify system design, a wide range of port types and sizes is available. B Series auxiliary gas bottles are supplied with BSPP ports as standard; ISO, metric and SAE threaded and metric flanged ports to ISO 6162 are available to special order.

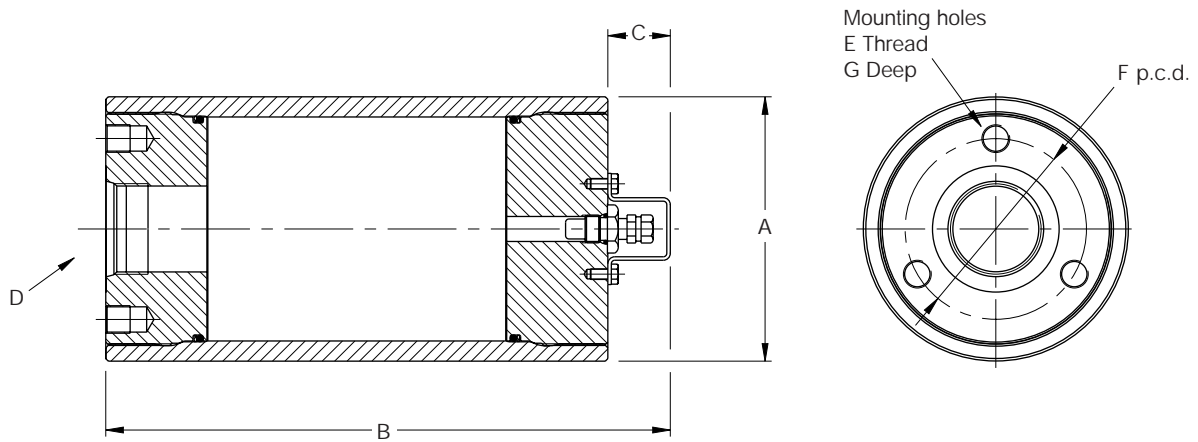

250 Bar B Series Gas Bottle with CE Approval

250 Bar Models, Capacities and Dimensions

Model	Code <small>See Page 34</small>	Bore Ø	Volume Litres	A	B	C	D – Gas Port BSPP	E 1	F	G	Weight kg
B4	0058	102.4	1.5	121	295	29	G1	M12	82	18	13
	0116		2.5		411						16
	0231		4.0		640						21
	0347		6.0		871						27
	0578		10		1330						39
B6	0231	146.9	5.0	175	442	29	G1½	M12	110	18	30
	0347		7.0		554						36
	0578		11		778						48
	0924		17		1113						67
	1155		20		1337						79
	1733		30		1896						107
	2310		40		2454						146

¹ B Series 250 bar gas bottles are supplied as standard with the metric threaded mounting holes shown in the table. They are also available with inch pattern mounting holes, indicated by the Design Number in the model code – see page 34.

Gas Valves

The standard gas charging valve fitted to B Series 250 and 350 bar auxiliary gas bottles is a cored-type gas valve, rated at 350 bar. A mechanically opened and closed poppet-type gas valve cartridge, also rated at 350 bar, is available as an option.

Both types of charging valve may be used with the Charging and Gauging Kit illustrated on page 32.

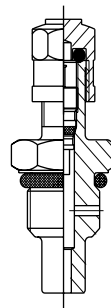

Standard Cored-Type Gas Valve

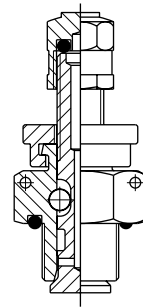

Optional Poppet-Type Gas Valve

All dimensions are in millimetres unless otherwise stated.

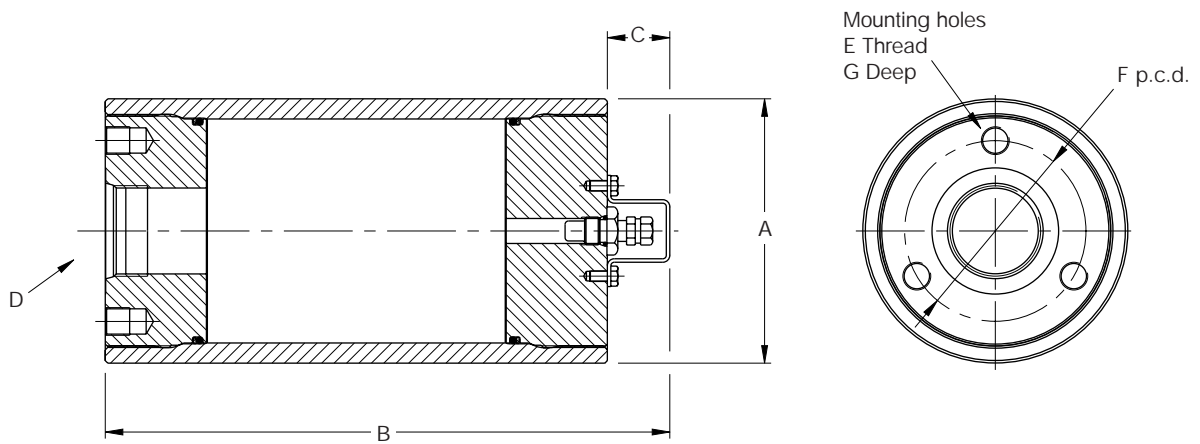

350 Bar B Series Gas Bottle with CE Approval

350 Bar Models, Capacities and Dimensions

Model	Code <small>See Page 32</small>	Bore Ø	Volume Litres	A	B	C	D – Gas Port BSPP	E ¹	F	G	Weight kg
B4	0058	102.4	1.5	127	306	29	G1	M12	82	18	13
	0116		2.5		422						16
	0231		4.0		651						21
	0347		6.0		882						27
	0578		10		1342						39
B6	0231	146.9	5.0	180	487	29	G1½	M12	110	18	30
	0347		7.0		600						36
	0578		11		824						48
	0924		17		1159						67
	1155		20		1383						79
	1733		30		1942						107
	2310		40		2500						146

¹ B Series 350 bar gas bottles are supplied as standard with the metric threaded mounting holes shown in the table. They are also available with inch pattern mounting holes, indicated by the Design Number in the model code – see page 34.

Safety Fuses

Safety fuses are available as a safety feature on accumulators and gas bottles to prevent over-pressurization of gas due to external heat or excess hydraulic pressure. They comprise a housing incorporating a disk which is calibrated to rupture at a pre-determined pressure, which should be specified by the customer at the time of ordering. Please contact the factory for further information.

All dimensions are in millimetres unless otherwise stated.

Optional Threaded Ports

BSPP ¹			Metric to DIN 3852-1			Metric to ISO 6149-1			SAE Thread		
Thread Size	From Model	Code	Thread Size	From Model	Code	Thread Size	From Model	Code	Thread Size	From Model	Code
G ³ / ₄	All Models	RC	M14	All Models	GA	M14	All Models	YA	#5	All Models	TA
G1		RD	M18		GB	M18		YB	#6		TB
G1 ¹ / ₄		RE	M22		GC	M22		YC	#8		TC
G1 ¹ / ₂		RF	M27		GD	M27		YD	#10		TI
G2		RG	M33		GE	M33		YE	#12		TD
-		-	M42		GF	M42		YF	#16		TE
-		-	-		-	-		-	#20		TF
-		-	-		-	-		-	#24		TG
-		-	-		-	-		-	-		-

¹ Where the required port is the standard BSPP size for the gas bottle bore diameter chosen (see dimension D, pages 30 and 31), the port fields in the model code should be left blank – see page 34.

Optional Flanged Ports

CE-approved B Series gas bottles are available with metric flange ports to ISO 6162, as shown in the table opposite. B Series gas bottles are also available with inch pattern flange ports to ISO 6162 – please consult the factory for details.

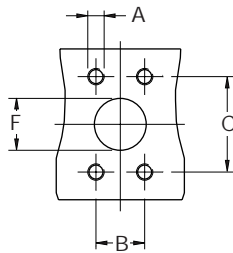

Flange Ports to ISO 6162						
Flange Size	From Model	A	B ±0.25	C ±0.25	F	Code
DN13	All Models	M8	17.5	38.1	13	MT
DN19		M10	22.3	47.6	19	MU
DN25		M10	26.2	52.4	25	MV
DN32		M10	30.2	58.7	32	MW
DN38		M16	35.7	69.9	38	MJ
DN51		M12	42.9	77.8	51	ML

Charging and Gauging

The charging and gauging assemblies listed in the table are suitable for use with both the standard cored-type gas valve and the optional poppet type. Each kit contains a UCA assembly incorporating a gas valve, bleed valve and gas chuck, and a 3m long charging hose with standard nitrogen bottle fittings. The kit includes 25 bar and 250 bar pressure gauges, to permit easy monitoring of the gas precharge.

Territory	Gas Bottle Fitting	Part No.
UK	5/8 BSP (male)	UCA 02
France	W 21.7 x 1/14" (female)	UCA 04
Germany	W 24.32 x 1/14" (female)	UCA 01
Italy	W 21.7 x 1/14" (male)	UCA 05
US	0.960 x 1/14" (male)	UCA 03

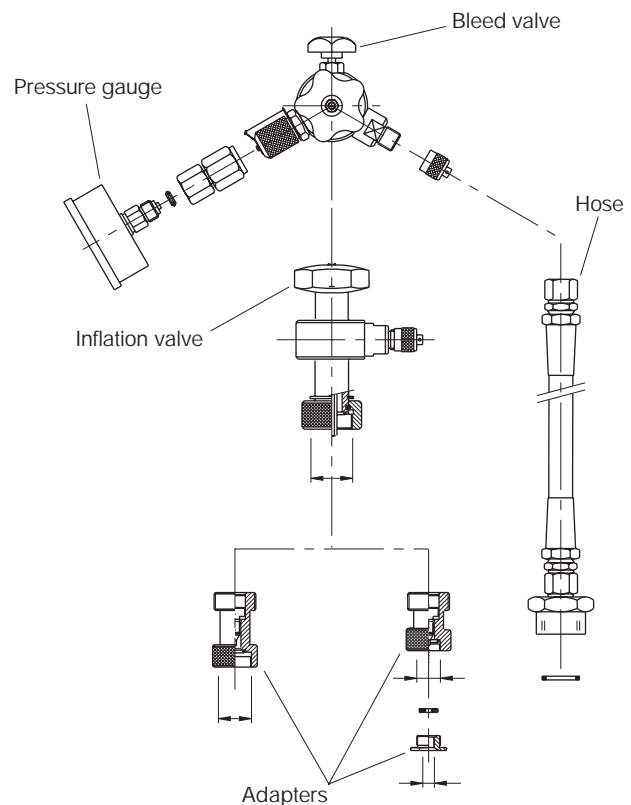

All dimensions are in millimetres unless otherwise stated.

Operating Temperatures and Fluid Media

B Series auxiliary gas bottles are fitted as standard with nitrile (NBR) O-ring seals. A range of alternative seal materials is available for use at extreme temperatures, as shown in the table. Other seals are also available for use in exceptional conditions – please consult the factory with details of the application. The shells of Parker's B series gas bottles are CE approved for operation at temperatures between -10°C and +150°C.

Seal Type	Code	Temperature Range
Nitrile (NBR)	K	-30°C to +75°C
Fluorocarbon Elastomer (FPM)	E	-25°C to +120°C
Low Temperature Nitrile (NBR)	Q	-45°C to +70°C

Gas Bottle Seal Kits

Seal kits are available for all B Series auxiliary gas bottles. When ordering seal kits, please supply the complete model number from the identification plate and specify the temperature at which the gas bottle is to be used.

Parts List

- 1 Shell
- 2 Gas cap with port
- 3 Gas cap for gas valve
- 4 Gas cap O-ring
- 5 Gas cap O-ring back-up washer
- 6 Gas valve
- 7 Gas valve O-ring
- 8 Gas valve protector
- 9 Gas valve protector screw

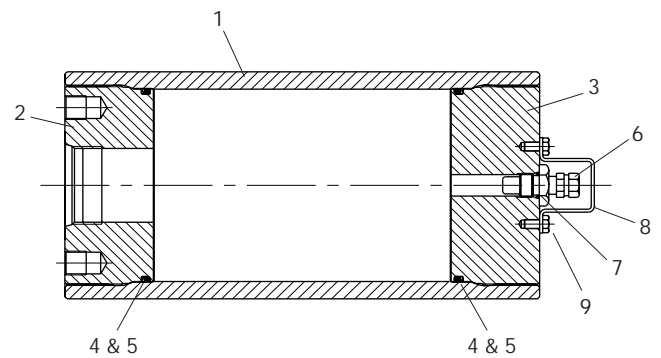

The seal kits listed contain items 4, 5 and 7.

Model	Seal Material		
	Nitrile NBR	Fluorocarbon Elastomer FPM	Low Temp. Nitrile NBR
B4	CB0400K000	CB0400E000	CB0400Q000
B6	CB0600K000	CB0600E000	CB0600Q000

'U' Bolts for Gas Bottles

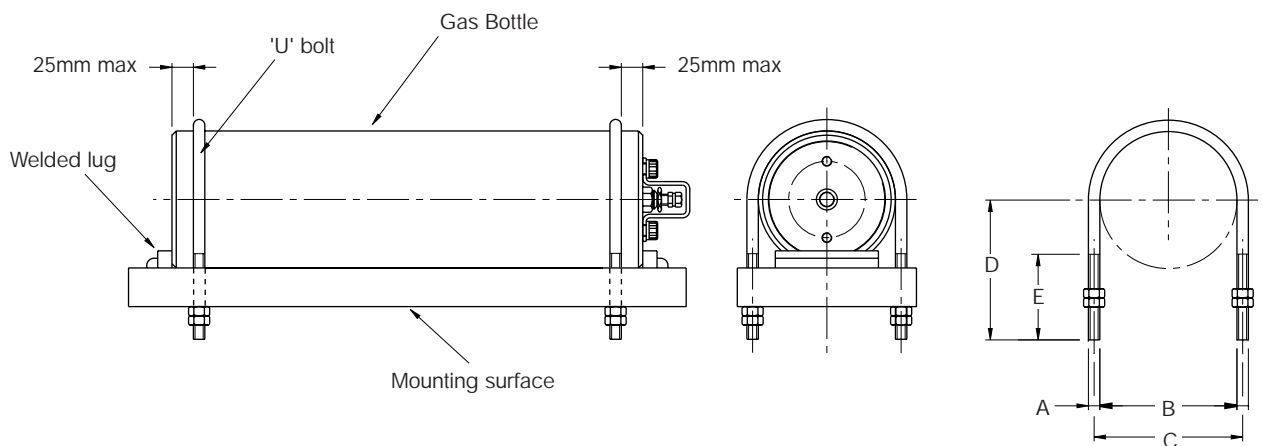

Model	Pressure Rating	Part No.	A	B	C	D	E
B4	250 350	PE1093-2	M12 x 1.75	128	140	114	76
B6	250 350	PE1093-3	M16 x 2	180	196	155	95

Note: 'U' bolts should never be mounted more than 25mm from the end of the gas bottle to avoid deformation of the shell.

All dimensions are in millimetres unless otherwise stated.

Model Numbers

Each Parker gas bottle is assigned a model number which represents the features selected. To develop a model number, identify the relevant characters from the table below and enter them in the sequence shown in the example.

Gas Port Modifications

For gas bottles with non-standard ports, specify special ports and use the appropriate port code from page 32. A typical model number for a gas bottle with ISO 6162 flanged ports at both ends would be:

B	6	E	S	0347	L	2	K	MV / MV
---	---	---	---	------	---	---	---	---------

Feature	Description	Page	Symbol	Example																
				B	6	E	S	1733	L	2	K	--	/	--						
Product Type	B Series auxiliary gas bottle	27	B	●																
Model	B4 100mm bore	30-31	4	●																
	B6 150mm bore		6	●																
Approval Type	CE approved ¹	5	E	●																
Options	Cored-type gas valve (standard) ²	30	S	●																
	Cored-type gas valve + safety fuse	30	F																	
	Poppet-type (MS) gas valve	30	M																	
	Poppet-type gas valve + safety fuse	30	P																	
Capacity (litres)	1.5 – B4 only	30-31	0058																	
	2.5 – B4 only		0116																	
	4.0 – B4 only		0231																	
	5.0 – B6 only		0231																	
	6.0 – B4 only		0347																	
	7.0 – B6 only		0347																	
	10 – B4 only		0578																	
	11 – B6 only		0578																	
	17 – B6 only		0924																	
	20 – B6 only		1155																	
30 – B6 only	1733																			
40 – B6 only	2310																			
Design Pressure ³	250 bar	30	L	●																
	350 bar	31	H	●																
Design Number	Metric mounting + BSPP ports (standard)	30-32	2	●																
	Inch mounting + SAE ports	30-32	1	●																
	Special ports	32	3	●																
	Specials (Parker assigned design number)	-	###	●																
Seal Compound	Nitrile (NBR)	33	K	●																
	Fluorocarbon Elastomer (FPM)	33	E	●																
	Low temperature nitrile (NBR)	33	Q	●																
	Special – please specify	33	S	●																
Hydraulic port specification		See page 32		●																
Gas port specification (no gas valve supplied)		See page 32		●																

¹ Other approvals are available to order – please consult the factory.

² Where a gas port is specified, no gas valve will be supplied.

³ For other pressure ratings, please consult the factory.

BP Series Gas Bottles

- Premium quality construction for demanding industrial applications
- CE approved to European Standard 97/23/EC
- 250 and 350 bar working pressures
- Gas volumes from 8.5 to 322 litres
- Bore/length combinations to suit available space
- High flow ports for rapid cycling performance
- Wide range of port options



Contents

250 bar gas bottles	38
350 bar gas bottles	39

BP Series Auxiliary Gas Bottles

Where space or constructional limitations prevent the installation of an accumulator large enough to deliver the flow rate required, a smaller accumulator may be used by connecting it to an auxiliary gas bottle which can be located elsewhere. This arrangement enables very high flow rates to be achieved while allowing the greater part of the accumulator's capacity to be given over to fluid. Because of the large precharge 'reservoir' provided by one or more auxiliary gas bottles, gas pressure is relatively constant over the full discharge cycle of the accumulator.

Where an accumulator is used with an auxiliary gas bottle, the travel of the accumulator piston must be carefully calculated to avoid impact with the accumulator caps. The accumulator gas port should be at least the same size as the hydraulic port of the accumulator.

Parker's BP Series auxiliary gas bottles are a compact, robust design which can be used singly or in combination to provide the large capacities and high flow rates required in demanding applications such as die casting and plastic injection moulding. A wide range of bore/length combinations enables the right volume to be selected in a size that will optimise the use of available space, while a choice of port styles simplifies connection.

250 and 350 Bar Pressure Ratings

BP Series auxiliary gas bottles are available in two different pressure ratings, to suit maximum working pressures of 250 and 350 bar. The same premium quality design and technical features guarantee optimum performance and service life from every model in each of the ranges, while differing wall thicknesses allow the designer to specify precisely the right performance envelope for the application.

Specification

Max. working pressures	250 and 350 bar
Working temp. range	-10 to +80°C (to +150°C on request)
Fluid volumes	8.5– 322 litres
Bore sizes	180, 250 and 360mm
Port style	BSPP (standard – others on request)
Gas valve	350 bar rated poppet type
Approval	CE (standard – others on request)

Materials

- Shell – high strength steel
- End caps – steel
- Seals – NBR (standard): other compounds to suit application
- Gas valve assembly – stainless steel
- Gas valve protector – steel
- Paint finish – black primer, suitable for epoxy paint finishes (standard) – other finishes on request

Custom Designs

For unique applications and hostile environments, different designs, materials and finishes can be supplied. Please contact our engineering department to discuss custom solutions to individual application requirements.

Available Options

A wide variety of options is available for BP Series gas bottles, including:

- Port styles and sizes
- O-ring seal compounds
- Safety fuses
- Mounting systems
- Certifications to suit different market requirements

Calculating Accumulator and Gas Bottle Size

Accurate calculation of accumulator and gas bottle size requires many factors to be considered – the working volume of oil, ambient and maximum operating temperatures, the working pressure range etc. In addition, correction factors must be applied to allow for temperature compensation between the ambient and gas temperatures, and the consequent effect on precharge pressure in the accumulator. Where the working cycle is sufficiently rapid that no heat transfer takes place, the process is termed *adiabatic*. Conversely, where the process takes place at a constant temperature, it is termed *isothermal*. Calculations and sizing charts which enable the designer to compensate for these differing conditions are shown on page 43.

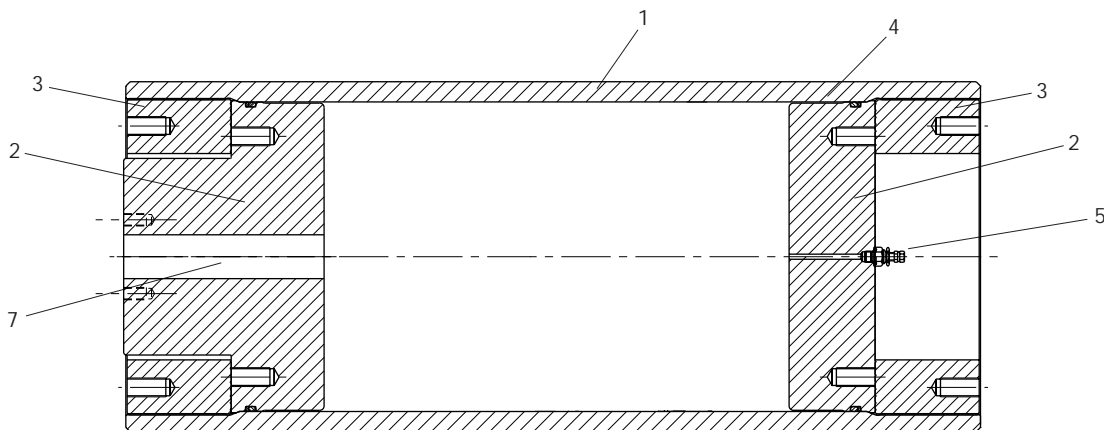

360mm Bore BP Series Gas Bottle with Flange Port

See Page 38 for cutaway view of 180/250mm bore models

Features and Benefits

Parker’s BP Series auxiliary gas bottles share their construction with AP Series accumulators, and many of the design features highlighted on page 19 apply also to these gas bottles.

Auxiliary gas bottles may be used singly to supplement/replace the gas storage capacity of the accumulator, or they may be manifolded together to provide a larger reservoir of gas pressure, if required. Where gas bottles are connected by a manifold, only one bottle need be fitted with a gas valve for charging purposes.

1, 2 & 3 Shell and Caps

Compact, rugged steel shell and end caps will survive even the toughest industrial environment, to provide reliable service year after year. 180mm and 250mm bore gas bottles feature threaded caps to minimize downtime and simplify maintenance, permitting quick and easy replacement of O-ring seals in the unlikely event of replacement being required. 360mm bore units (illustrated) use a screwed ring (3) to retain the gas caps, reducing the mass of parts handled during maintenance and providing additional protection for the gas valve.

4 Safety Bleed Grooves

A bleed groove in the gas cap progressively releases unrelieved gas pressure in the accumulator as the gas cap is unscrewed.

Note: to avoid the risk of damage or injury, an accumulator must always be discharged before disassembly.

5 Gas Valve

To avoid the risk of injury or damage, a gas bottle must be discharged before disassembling. For added safety, the gas valves fitted by Parker vent progressively as they are unscrewed. A robust, mechanically opened/closed poppet-type gas valve rated at 350 bar is fitted as standard to all BP Series auxiliary gas bottles.

6 Gas Valve Protector

To prevent accidental – and potentially hazardous – damage to the gas valve, 180mm and 250mm bore BP Series gas bottles are fitted with a steel gas valve protector to reduce the risk to the valve from external impact. The gas valve on 360mm bore models is recessed within the shell to reduce the risk of damage.

7 Ports

To provide the required gas transfer rate and simplify system design, a wide range of port types and sizes is available. BSPP ports are fitted as standard; metric flanged ports to ISO 6162 and ISO 6164 are available as an option.

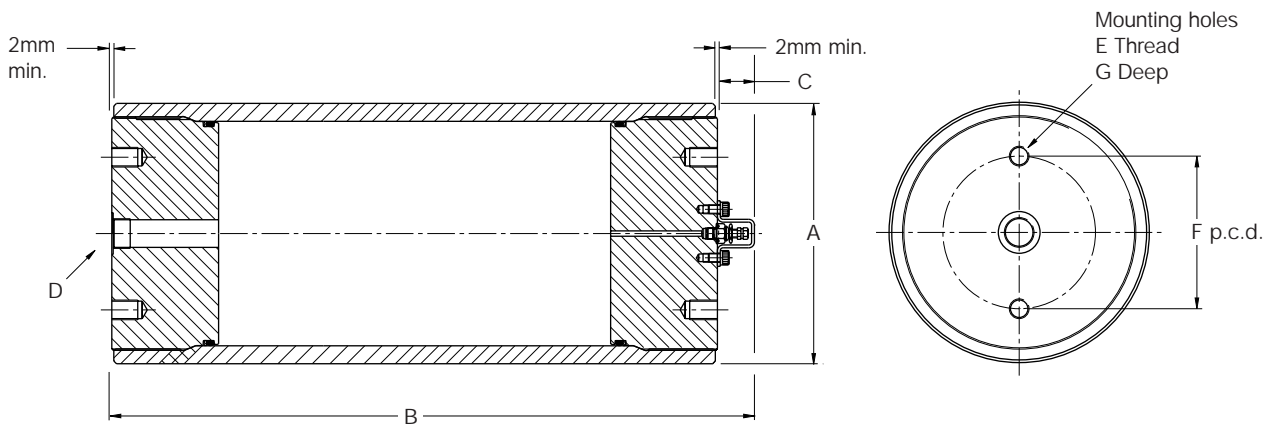

**250 and 350 Bar BP Series Gas Bottles,
 180 and 250mm Bore Sizes**

250 Bar Models, Capacities and Dimensions

Model	Code See page 42	Bore Ø	Volume Litres	A	B	C	D BSPP	E	F	G	Weight kg
BP180	008	180	8.7	207.0	591	42	G1½	M16 x 2	140	20	79
	010		10.7		669						84
	012		12.7		748						89
	017		17.7		944						102
	022		22.7		1141						114
	027		27.7		1337						127
	032		32.7		1534						139
	042		42.7		1927						164
	052		52.7		2320						189
	062		62.7		2713						214
082	82.7	3499	264								
BP250	037	250	37.4	290.0	1041	42	G1½	M22 x 2.5	170	30	229
	047		47.4		1245						256
	057		57.4		1449						282
	067		67.4		1652						309
	087		87.4		2060						363
	107		107.4		2467						416
	157		157.4		3486						550
BP360	122	360	122	407.0	1657 ¹	N/A	G1½	M22 x 2.5	280	45	593
	172		172		2149 ¹						696
	222		222		2640 ¹						799
	272		272		3131 ¹						902
	322		322		3622 ¹						1005

¹ The mounting face of BP360 Series gas bottles fitted with flange ports extends 2mm beyond the end of the shell.

Gas Valves

The standard gas charging valve fitted to 250 and 350 bar BP Series auxiliary gas bottles is a mechanically opened and closed poppet-type cartridge valve, rated at 350 bar. This charging valve may be used with the Charging and Gauging Kit illustrated on page 40.

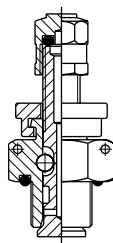

Safety Fuses

Safety fuses are available as a safety feature on accumulators and gas bottles to prevent over-pressurization of gas due to external heat or excess hydraulic pressure. They comprise a housing incorporating a disk which is calibrated to rupture at a pre-determined pressure, which should be specified by the customer at the time of ordering. Please contact the factory for further information.

All dimensions are in millimetres unless otherwise stated.

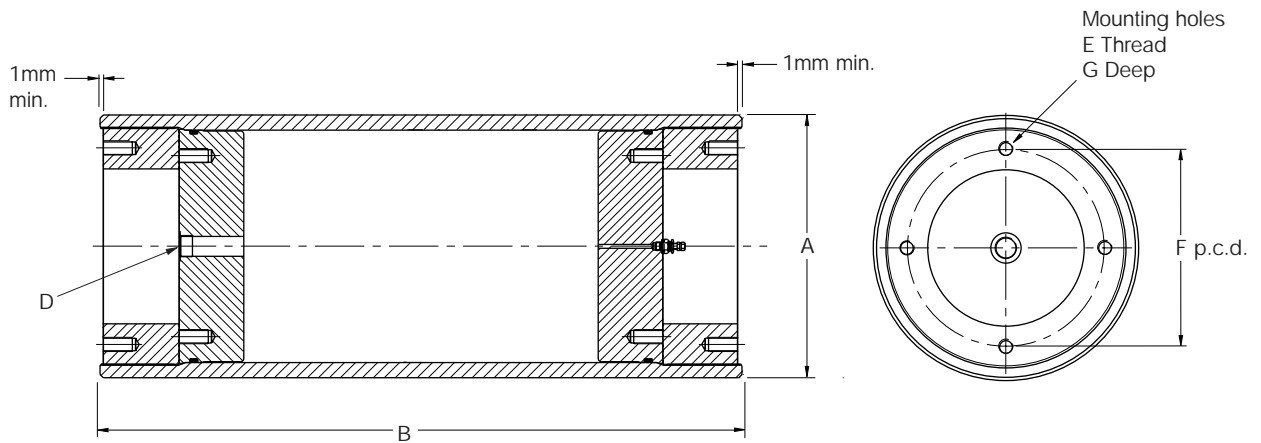

**250 and 350 Bar BP Series Gas Bottles,
 360mm Bore size**

350 Bar Models, Capacities and Dimensions

Model	Code <small>See page 42</small>	Bore Ø	Volume Litres	A	B	C	D BSPP	E	F	G	Weight kg	
BP180	008	180	8.7	220.0	591	42	G1 ^{1/2}	M16 x 2	140	20	98	
	010		10.7		669						105	
	012		12.7		748						113	
	017		17.7		944						132	
	022		22.7		1141						151	
	027		27.7		1337						171	
	032		32.7		1534						190	
	042		42.7		1927						228	
	052		52.7		2320						266	
	062		62.7		2713						304	
082	82.7	3499	381									
BP250	037	250	37.4	310.0	1041	42	G1 ^{1/2}	M22 x 2.5	170	30	301	
	047		47.4								1245	343
	057		57.4								1449	385
	067		67.4								1652	426
	087		87.4								2060	510
	107		107.4								2467	593
	157		157.4								3486	801
BP360	122	360	122	436.0	1657 ¹	N/A	G1 ^{1/2}	M22 x 2.5	280	45	856	
	172		172								2149 ¹	1037
	222		222								2640 ¹	1218
	272		272								3131 ¹	1399
	322		322								3622 ¹	1580

¹ The mounting face of BP360 Series gas bottles fitted with flange ports extends 2mm beyond the end of the shell.

Threaded Gas Ports

The G1^{1/2} BSPP ports shown above are supplied as standard at the gas ends of BP Series gas bottles. A range of optional threaded and flanged ports is also available, as shown. All ports are specified by adding the relevant code to the accumulator model number – see page 42.

BSPP Threaded Ports

Thread Size	From Model	Code
G1	All models	RD
G1 ^{1/4}		RE
G1 ^{1/2} (standard)		RF
G2		RG

All dimensions are in millimetres unless otherwise stated.

Optional Flanged Ports, 400 Bar Series

Bore Ø	ISO Port Style	DN10	DN13	DN19	DN25	DN32	DN38	DN51	DN56	DN63	DN70	DN80
180	ISO 6162											
	ISO 6164											
250	ISO 6162											
	ISO 6164											
360	ISO 6162											
	ISO 6164											

Flanged Port Dimensions

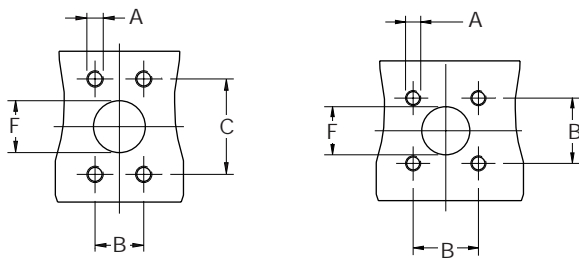

ISO 6162

ISO 6164

Flange Ports to ISO 6164 - 400 Bar Series				
Flange Size	A	B ±0.25	F +0.0 -1.5	Code
DN10	M6 x 1	24.7	10.0	SD
DN13	M8 x 1.25	29.7	13.0	SE
DN19	M8 x 1.25	35.4	19.0	SF
DN25	M10 x 1.5	43.8	25.0	SG
DN32	M12 x 1.75	51.6	32.0	SH
DN38	M16 x 2	60.1	38.0	SP
DN51	M16 x 2	69.3	51.0	SQ
DN56	M20 x 2.5	83.4	56.0	SX
DN63	M24 x 3	102.5	63.0	SR
DN70	M24 x 3	113.1	70.0	SY
DN80	M30 x 3.5	123.7	80.0	SZ

Flange Ports to ISO 6162 - 400 Bar Series					
Flange Size	A	B ±0.25	C ±0.25	F	Code
DN13	M8 x 1.25	18.2	40.5	13	ME
DN19	M10 x 1.5	23.8	50.8	19	MF
DN25	M12 x 1.75	27.8	57.2	25	MG
DN32	M12 x 1.75	31.8	66.6	32	MH
DN38	M16 x 2	36.5	79.3	38	MP
DN51	M20 x 2.5	44.5	96.8	51	MQ

Charging and Gauging

The charging and gauging assemblies listed in the table are suitable for use with the standard poppet-type gas valve. Each kit contains a UCA assembly incorporating a gas valve, bleed valve and gas chuck, and a 3m long charging hose with standard nitrogen bottle fittings. The kit includes 25 bar and 250 bar pressure gauges, to permit easy monitoring of the gas precharge.

Territory	Gas Bottle Fitting	Part No.
UK	5/8 BSP (male)	UCA 02
France	W 21.7 x 1/14" (female)	UCA 04
Germany	W 24.32 x 1/14" (female)	UCA 01
Italy	W 21.7 x 1/14" (male)	UCA 05
US	0.960 x 1/14" (male)	UCA 03

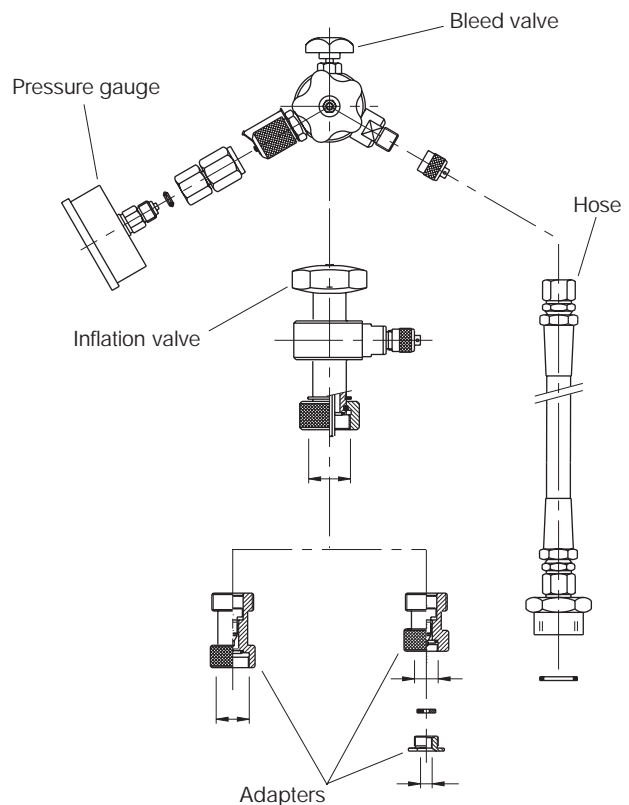

All dimensions are in millimetres unless otherwise stated.

Seals

BP Series auxiliary gas bottles are fitted as standard with nitrile (NBR) O-ring seals. A range of alternative seal materials is available for use at extreme temperatures, as shown in the table. Other seals are also available for use in exceptional conditions – please consult the factory with details of the application.

Seal Type	Code	Temperature Range
Nitrile (NBR)	K	-30°C to +75°C
Fluorocarbon Elastomer (FPM)	E	-25°C to +150°C
Low Temperature Nitrile (NBR)	Q	-45°C to +70°C

Gas Bottle Seal Kits

O-ring seal kits are available for all BP Series gas bottles. When ordering seal kits, please supply the complete model number from the identification plate and specify the temperature at which the gas bottle is to be used.

The seal kits listed below contain items 5, 6 and 8.

Parts List

- 1 Shell
- 2 Gas cap with port
- 3 Gas cap for gas valve
- 4 Retaining ring (BP360 only)
- 5 Cap O-ring
- 6 Cap O-ring back-up washer
- 7 Gas valve
- 8 Gas valve O-ring
- 9 Gas valve protector (not BP360)
- 10 Gas valve protector screw (not BP360)

Model	Seal Material		
	Nitrile NBR	Fluorocarbon Elastomer FPM	Low Temp. Nitrile NBR
BP180	CB180BPK	CB180BPE	CB180BPQ
BP250	CB250BPK	CB250BPE	CB250BPQ
BP360	CB360BPK	CB360BPE	CB360BPQ

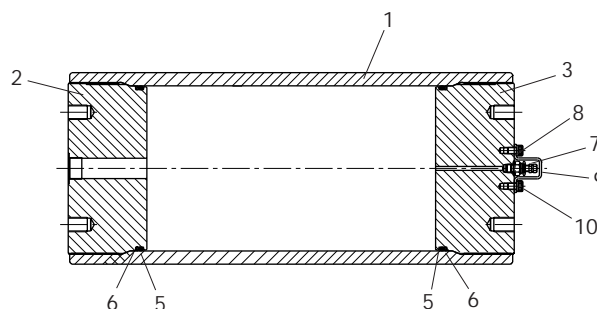

180mm and 250mm Bore Gas Bottles

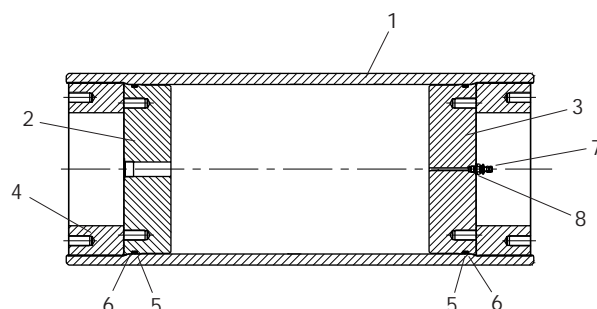

360mm Bore Gas Bottles

'U' Bolts for Gas Bottles

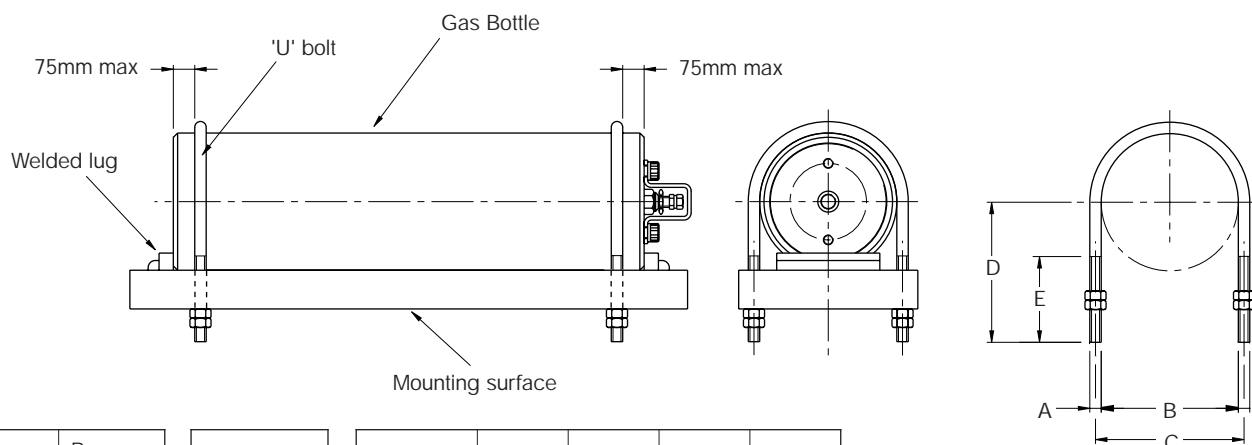

Model	Pressure Rating	Part No.	A	B	C	D	E
BP180	250	PE1093-5	M16 x 2	210	226	180	95
	350	PE1093-8		224	240	185	
BP250	250	PE1093-6	M20 x 2.5	286	306	240	115
	350	PE1093-9		312	332	256	
BP360	250	PE1093-10	M27 x 3	408	435	290	135
	350	PE1093-11		438	465	300	

Note: 'U' bolts should never be mounted more than 75mm from the end of the gas bottle to avoid deformation of the shell.

All dimensions are in millimetres unless otherwise stated.

Model Numbers

Each Parker gas bottle is assigned a model number which represents the features selected. To develop a model number, identify the relevant characters from the table below and enter them in the sequence shown in the example.

Gas Port Modifications

For gas bottles with non-standard ports, specify special ports and use the appropriate port code from page 40. A typical model number for a gas bottle with ISO 6164 gas ports would be:

BP	180	E	M	082	L	2	K	SF / SF
----	-----	---	---	-----	---	---	---	---------

Feature	Description	Page	Symbol	Example										
Product Type	BP Series auxiliary gas bottle	35	BP	BP	250	E	M	057	L	2	K	--	/	--
Model	180mm bore 250mm bore 360mm bore	38-39	180 250 360	●	●	●	●	●	●	●	●	●	●	●
Approval Type	CE approved ¹	5	E	●										
Options	Poppet-type (MS) gas valve (standard) ² Poppet-type gas valve + safety fuse	38 38	M P	●										
Capacity (litres)	8.7 – 180mm bore 10.7 – 180mm bore 12.7 – 180mm bore 17.7 – 180mm bore 22.7 – 180mm bore 27.7 – 180mm bore 32.7 – 180mm bore 37.4 – 250mm bore 42.7 – 180mm bore 47.4 – 250mm bore 52.7 – 180mm bore 57.4 – 250mm bore 62.7 – 180mm bore 67.4 – 250mm bore 82.7 – 180mm bore 87.4 – 250mm bore 107.4 – 250mm bore 122 – 360mm bore 157.4 – 250mm bore 172 – 360mm bore 222 – 360mm bore 272 – 360mm bore 322 – 360mm bore	38, 39	008 010 012 017 022 027 032 037 042 047 052 057 062 067 082 087 107 122 157 172 222 272 322	●										
Design Pressure ³	250 bar 350 bar	38 39	L H	●										
Design Number	Standard Specials (Parker assigned design number)	38-39 40	2 ###	●										
Seal Compound	Nitrile (NBR) Fluorocarbon Elastomer (FPM) Low Temperature Nitrile (NBR) Special – please specify	41 41 41 41	K E Q S	●										
Hydraulic port specification		See page 40		●										
Gas port specification (no gas valve supplied)		See page 40		●										

¹ Other approvals are available to order – please consult the factory.
² Where a gas port is specified, no gas valve will be supplied.
³ For other pressure ratings, please consult the factory.

Accumulator Sizing Charts

The charts shown below are used to estimate the size of piston accumulator required to provide a given volume of fluid discharge from the accumulator. The curves are based on the following formulae:-

$$\Delta V = \frac{0.855 V_o [(P_2/P_1)^{1/n} - 1]}{(P_2/P_1)^{1/f}}$$

where:

ΔV = volume of fluid discharged

V_o = Accumulator size

f = charge coefficient

n = discharge coefficient

P_2 = maximum system pressure

P_1 = minimum system pressure

It is assumed the gas precharge pressure = 0.9 P_1

Isothermal and Adiabatic Operation

In constructing the curves, the following factors have been assumed.

For isothermal operation eg: slow charge and discharge time, f and $n = 1$

For adiabatic operation, eg: fast charge and discharge time, f and $n = 1.6$.

Note For most applications, the charts will provide a conservative estimate. In practice, the true charge and discharge coefficients will depend on the application, and may cause significant variations from the chart results. If in doubt, please contact our engineering department for a more detailed calculation.

Where the ratio P_2/P_1 exceeds 1.9, a fatigue analysis is necessary. Please contact our engineering department for further information.

Accumulator Sizing Chart $\Delta V = 0.1$ to 50 Litres

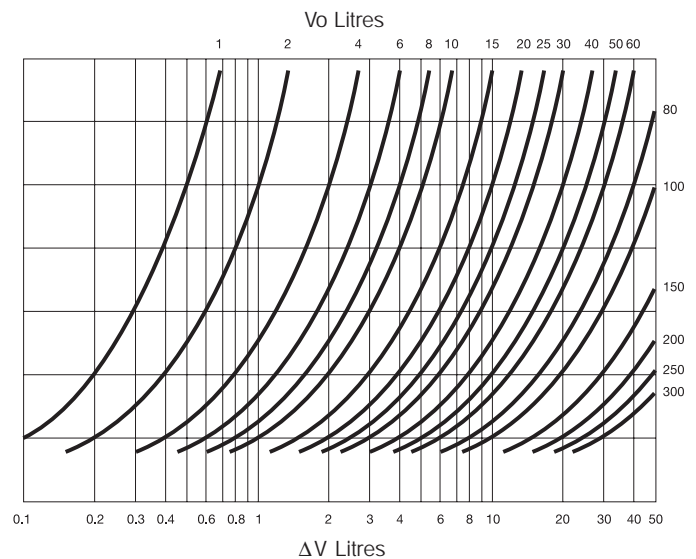
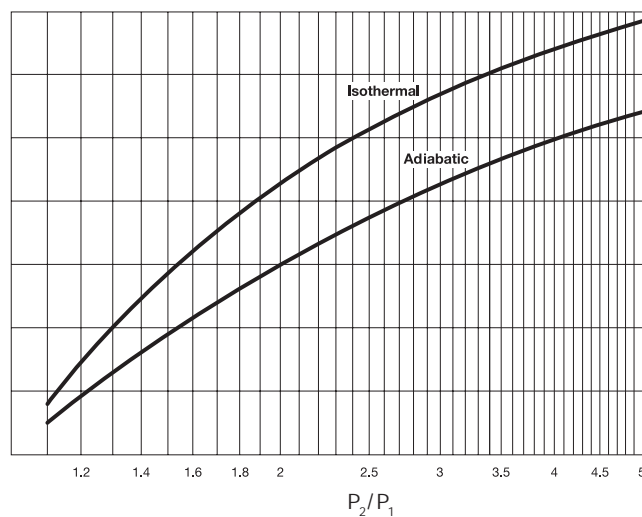

Accumulator Sizing Chart $\Delta V = 10$ to 200 Litres

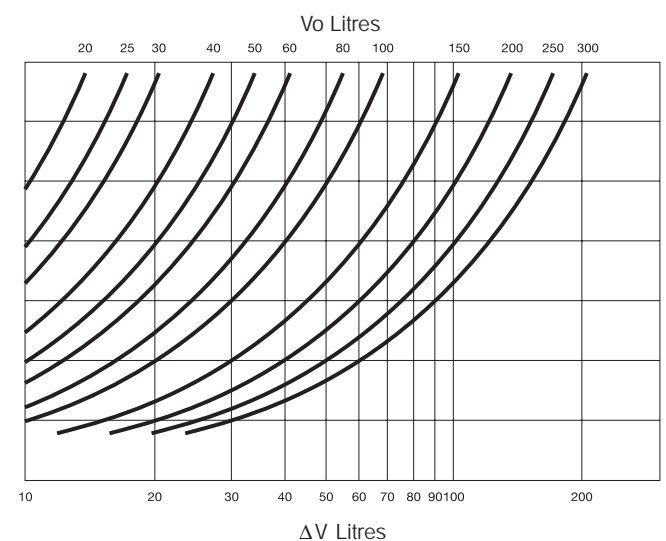
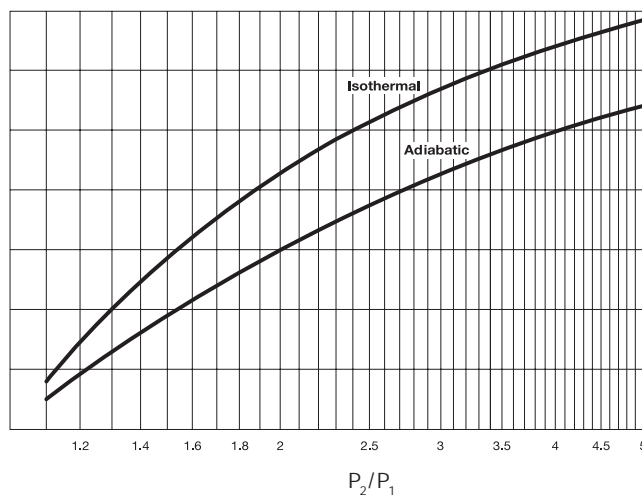

Cylinder Division Sales Offices

Austria – Marchtrenk

Parker Hannifin GmbH
Tel: (7242) 56921
Fax: (7242) 5692120

Netherlands – Oldenzaal

Parker Hannifin B.V.
Tel: (0) 541 585000
Fax: (0) 541 585459

Belgium – Nivelles

Parker Hannifin SA NV
Tel: 67 280 900
Fax: 67 280 999

Norway – Ski

Parker Hannifin A/S
Tel: (64) 91 10 00
Fax: (64) 91 10 90

Czech Republic – Prague

Parker Hannifin Corporation
Tel: (02) 830 85 221
Fax: (02) 830 85 360

Poland – Warsaw

Parker Hannifin Corp.
Tel: (22) 863 49 42
Fax: (22) 863 49 44

Denmark – Ishøj

Parker Hannifin Danmark A/S
Tel: 43 56 04 00
Fax: 43 73 31 07

Portugal – Leca da Palmeira

Parker Hannifin Portugal Lda.
Tel: (22) 999 7360
Fax: (22) 996 1527

Finland – Vantaa

Parker Hannifin Oy
Tel: 9 476 731
Fax: 9 476 73200

Spain – Madrid

Parker Hannifin Espana S.A.
Tel: (91) 675 73 00
Fax: (91) 675 77 11

France – Contamine-sur-Arve

Parker Hannifin SA
Tel: 4 50 25.80.25
Fax: 4 50 03.67.37

Sweden – Spånga

Parker Hannifin AB.
Tel: 08 5979 50 00
Fax: 08 5979 51 20

Germany – Cologne

Parker Hannifin GmbH
Tel: (221) 71720
Fax: (221) 7172219

Switzerland – Romanshorn

Hydrel A.G. Romanshorn
Tel: (714) 66 66 66
Fax: (714) 66 63 33

Hungary – Budapest

Parker Hannifin Corp.
Tel + Fax: 1 252 2539

Turkey – Istanbul

Hidroser Hidrolik - Pnömatik
Tel: (212) 886 72 70
Fax: (212) 886 69 35

Italy – Arsago-Seprio

Parker Hannifin S.p.A.
Tel: (331) 765611
Fax: (331) 765612

United Kingdom – Watford

Parker Hannifin Plc
Tel: (01923) 492000
Fax: (01923) 248557

Visit us at www.parker.com/uk

Need a Parker part?

Call Parker's European Product Information Centre
on 00800 27 27 5374