



Energy Efficiency in Hydraulics

Making savings with the differential cylinder

aerospace
climate control
electromechanical
filtration
fluid & gas handling
hydraulics
pneumatics
process control
sealing & shielding



ENGINEERING YOUR SUCCESS.

Note

This document and other information from Parker Hannifin GmbH & Co. KG, its subsidiaries, sales offices and authorized distributors provide product or system options for further investigation by users having technical expertise. Before you select or use any product or system it is important that you analyse all aspects of your application and review the information concerning the product or system in the current product catalogue. Due to the variety of operating conditions and applications for these products or systems, the user, through his own analysis and testing, is solely responsible for making the final selection of the products and systems and assuring that all performance and safety requirements of the application are met. The products are subject to change by Parker Hannifin GmbH & Co. KG at any time without notice.

Energy Efficiency in Hydraulics

Making savings with the differential cylinder

Hydraulic cylinders are often designed at the same time as the machine. The first choice is the compact differential cylinder with just one piston rod. The cylinder is adapted to the required forces for a defined supply pressure by sizing the cylinder surface areas. The circuit can also be used to influence the forces. In a standard circuit the cylinder sides are connected alternately with the supply pressure or the tank. The regenerative circuit returns the oil in the ring side back to the piston side as the cylinder moves out, meanwhile reducing the cylinder force and the amount of oil taken from the oil supply – which is why it is also called an “economiser circuit”.

Before talking about economising, we need to decide where exactly the savings are to be made. Cylinder actuators are either pump-controlled or valve-controlled. Pump control requires a particular drive motor and pump to be allocated to each cylinder. With valve control, the pressure is usually supplied to several actuators at once for reasons of cost: the cost of a drive motor and a pump are split between several cylinders. In other words, there is a saving. With pump control, the sys-

tem only generates the pressure and flow that are actually needed by the actuator. This too creates energy savings in operation, disregarding the initial investment for the drive motor and pump. Valve control supplies the cylinder with exactly the right amount of energy. Any energy supplied from the constant pressure network and not needed by the cylinder is converted into heat through throttling and removed by the flow of oil. Savings are also possible here, but the system must be carefully designed and arranged.

A cylinder achieves its maximum force when it is stationary. The maximum force is the influence of the supply pressure on the applicable cylinder surface areas. As soon as the cylinder moves, the forces are reduced by the portion of the supply pressure that is lost through throttling as a pressure drop at the valve. In an unloaded cylinder travelling at maximum speed, virtually all the energy introduced at the valve in the form of throttling losses is converted into heat. “Valve or throttling control” works by regulating the introduction of energy by throttling, and it is precisely this characteristic that gives it great potential for improving energy efficiency.

The cylinder and valve should be adapted as closely as possible to the load. Energy is saved when throttling is minimised. With less throttling, the force delivered by the cylinder is closer to the force required by the machine. There is a difference between adapting the force and adapting the speed. The force is adapted by changing the cylinder and rod diameter, while the speed is adapted by changing the size of the valve. Oversizing the cylinder diameter results in excessive energy consumption, as too much oil is supplied. On the other hand, if the system is arranged for excessive speed due to an oversized valve, the result is not an increase in energy consumption, but an increase in the possible speed range. Although reducing the valve stroke will set the desired speed, the position resolution of the valve stroke is reduced, with a detrimental effect on controllability. With a constant load and a smaller cylinder, the pressure drop at the valve must be smaller in order to overcome resistance. For cylinder actuators it is also true that operating at full load is more efficient than operating at partial load.

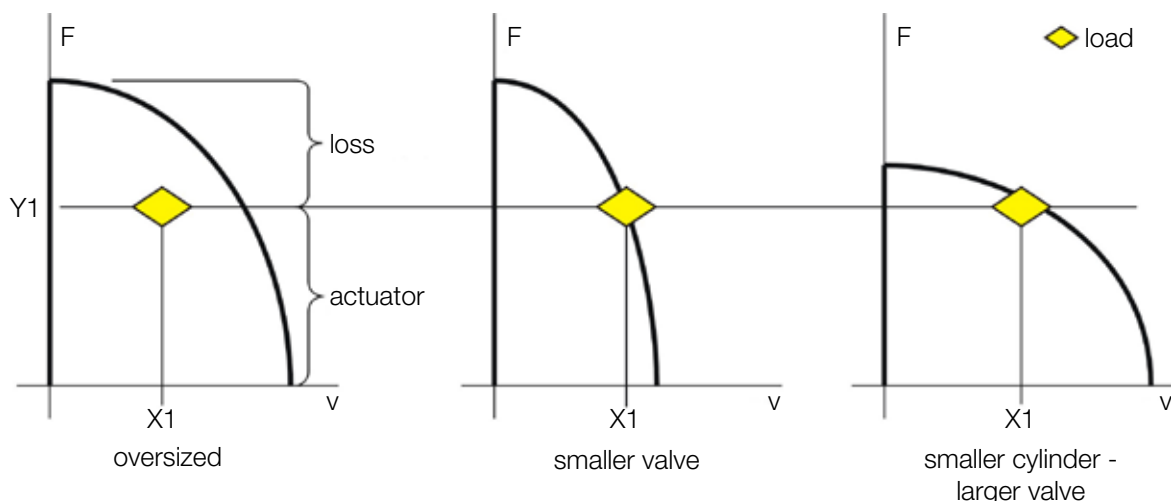

Adapting the cylinder and valve to the load

The force and speed are controlled by the supply of energy at the valve. Conventional wisdom states that for good controllability, there should be a power loss of one third at maximum speed. A valve-controlled cylinder actuator achieves maximum efficiency with a pressure drop of P_{load} / P_0 . Even today, nominal flows are still specified with 70 bar circuit pressure drop for a 210 bar supply pressure. This is a useful rule of thumb when designing a system, even though modern control technology, high-performance valves and economiser circuits can significantly reduce the losses.

Because each cylinder has two working surfaces, there is a direc-

tional element when the forces are adapted to the loads, and the speeds are adapted to the valve pistons via the diameters. The designer must have the freedom to choose the dimensions of the cylinder liner and rod, and to determine the diameters of the valve pistons. These are essential prerequisites for operating a valve-controlled cylinder actuator in a way that combines energy savings with effective control.

After sizing the cylinder surface areas and the throttling diameters in the valve, the third factor consists of the circuit for optimising adaptation to the loads. In a standard circuit the cylinder sides are connected alternately with the supply pressure or the tank.

The cylinder delivers its full force. A regenerative circuit returns the oil in the ring side back to the piston side as the cylinder moves out, reducing the cylinder force in this direction. This increases the ability to adapt the force to the loads. For example if the loads are equal in both directions, a cylinder with a surface area ratio of 2:1 combined with a regenerative circuit would make sense. The non-symmetrical differential cylinder works almost symmetrically in terms of force, speed and energy consumption. If the full force corresponding to the entire cylinder surface area is needed, for example in the extended end position, this is achieved by changing to the standard circuit.

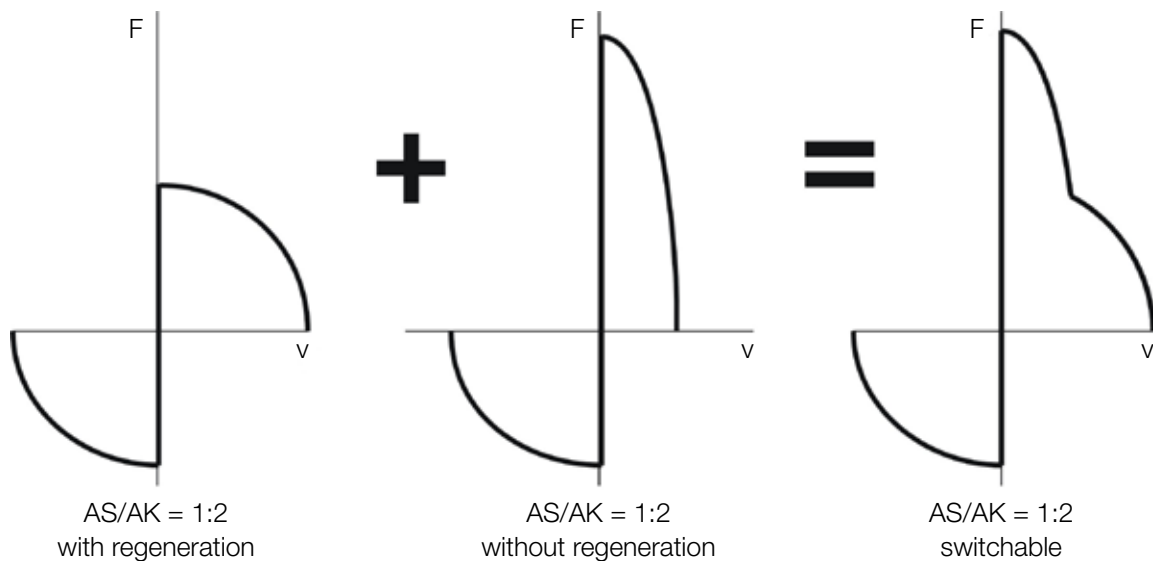

Force control with a combination circuit

With different combinations of cylinder surface area ratios, throttling diameters at the valve piston and circuit, there is a wide range of options for optimising the load and speed characteristics of a cylinder. It is worth repeating: the better the cylinder actuator is adapted to the load, the lower the energy consumption.

The standard circuit is already well known. It should be mentioned that with larger cylinder surface area ratios, the piston throttling diameters should be adapted to the flows in order to improve controllability.

The state of the art for regenerative circuits is a combination of a standard directional valve and two external check valves, returning the oil in the ring side through the pump connection (P-return) to the piston side. There is no longer a flow through one of the piston edges, turning the four-edge control into a three-edge control with familiar disadvantages in terms of regulation. Pulling loads can be arrested

P-return with external additional valves

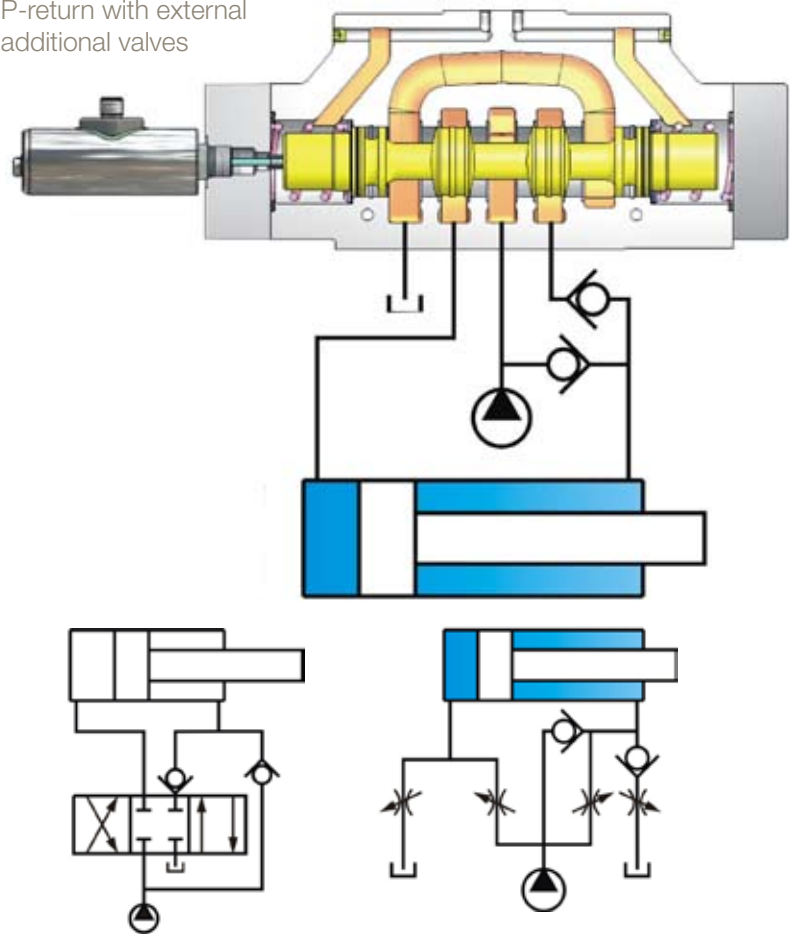

A-return with external additional valve

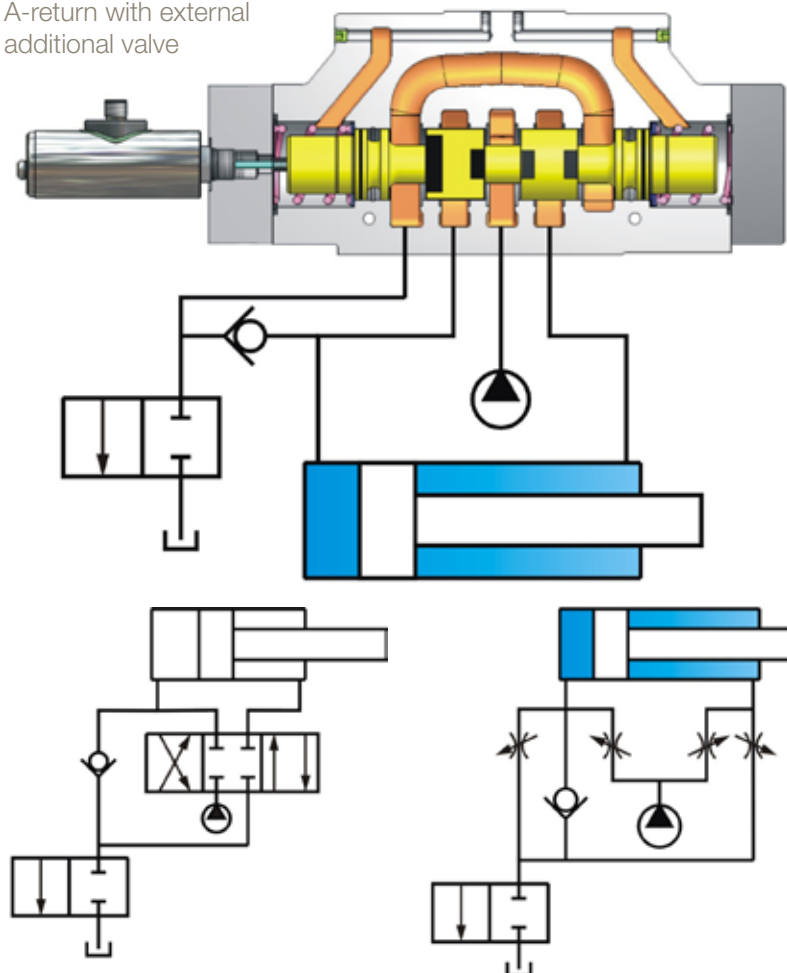

very effectively with this regenerative circuit, but the pressure is only influenced on one side of the cylinder. The regeneration is active at all times.

Regeneration below the pump pressure is possible with a combination of a standard directional valve, an external check valve in the tank connection, and an external check valve returning the oil in the ring side directly to the piston side (A-return) instead of to the tank. This arrangement is of limited usefulness for control systems because the check valve has to be actuated for each change of direction. Oil is not returned if the tank connection is open.

A special piston in a standard directional valve allows permanent regeneration without an external check valve. The oil in the ring side is returned to the piston side within the valve through the pump connection (P-return). Because there is a throttling edge of the piston between the cylinder and the pump, the pressure of the rod side is always higher than the pressure of the pump. As a result of load-dependent pressure intensification, the rod side of the cylinder and the directional valve may be exposed to twice the pump pressure. In practice, there are safety implications that significantly limit the full use of the permitted pressure of the components.

This model is also available with four-position pistons. In the extend phase, one position constitutes the standard circuit and the other position constitutes the regenerative circuit. Switching between the two modes is therefore

P-return with special piston

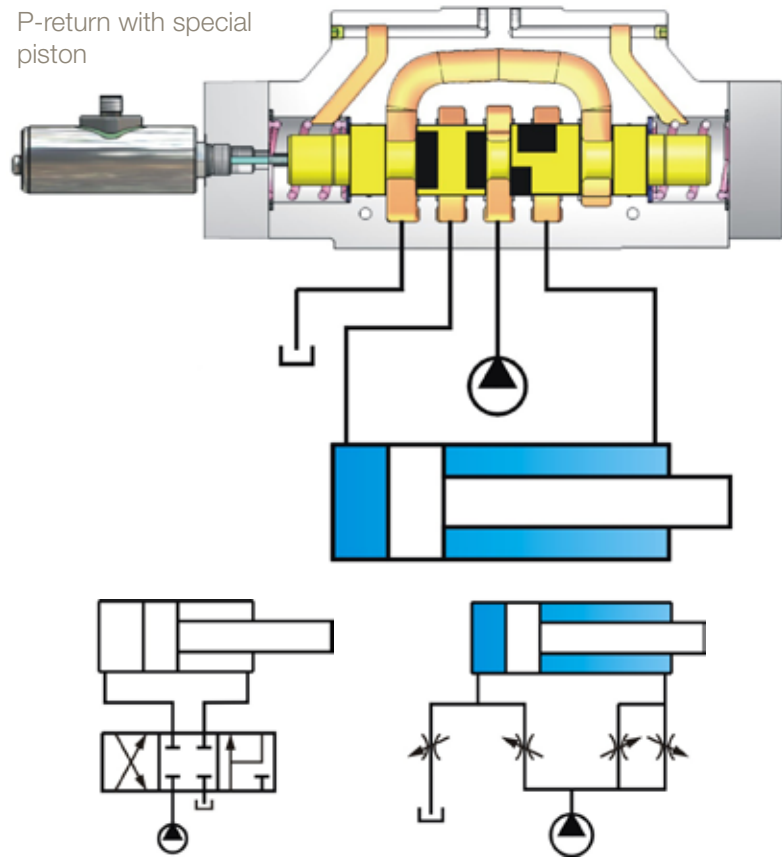

New A-regenerative circuit

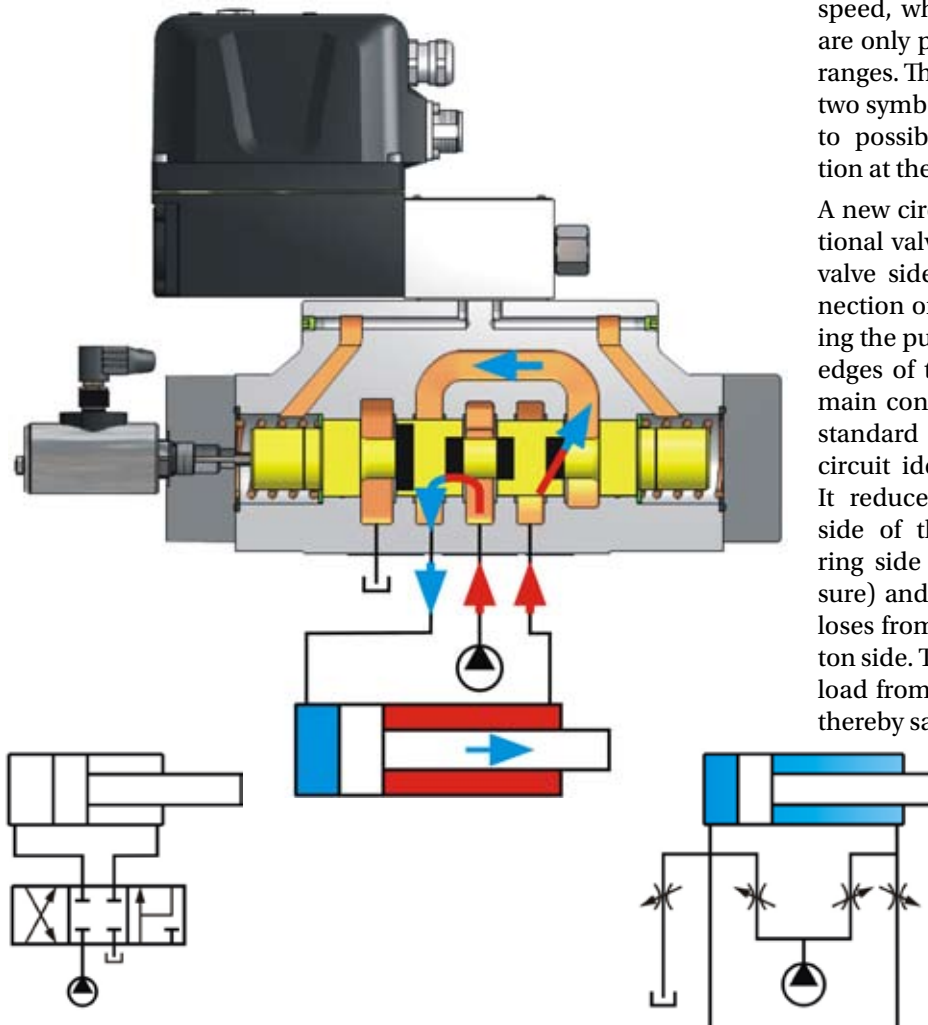

dependent on the piston stroke or speed, which means that savings are only possible in certain speed ranges. The transition between the two symbols is critical with regard to possible pressure intensification at the cylinder.

A new circuit in a standard directional valve returns the oil on the valve side directly to the A-connection on the piston side, avoiding the pump connection. All four edges of the directional valve remain constantly engaged, as in a standard circuit. This makes this circuit ideal for control systems. It reduces the pressure in ring side of the cylinder (maximum ring side pressure = pump pressure) and reduces the circulation losses from the rod side to the piston side. This reduces the pressure load from the cylinder and valve, thereby saving energy.

Two additional valves integrated with the standard directional valve mean that this new A-regenerative circuit can be switched to standard (A-hybrid circuit). Because switching is no longer dependent on the piston stroke, any speeds can be used in both circuit modes. Switching can be made dependent on the required force, for example. If the force in the regenerative circuit is insufficient, the system switches to the standard circuit. The low-loss return means that this circuit is compatible with cylinders with a wide range of surface area ratios. Switching can take place at any speed with no risk of pressure intensification for the cylinder. And switching between the two circuit modes is also risk-free: from standard to regenerative or from regenerative to standard. This ability to switch freely at any time allows for maximum energy savings without restricting the operating range.

Because the additional valves are installed on the upper side of the standard directional valve, the valve retains its standard connection configuration on its lower side, making it easy to use as a replacement for any other valve.

The competition includes electromechanical actuators with pump-controlled or valve-controlled hydraulic actuators. Electromechanical actuators and pump-controlled hydraulic actuators generate forces and speeds non-directionally. Differential cylinders combined with an A-hybrid can now — in one direction — step up a gear in terms of force, by freely switching to the full working surface area of the cylinder. This will guarantee them a special place among linear actuators in future.

Making savings with valve-controlled linear cylinder actuators has never been so easy. A directional valve with standard

New A-hybrid circuit

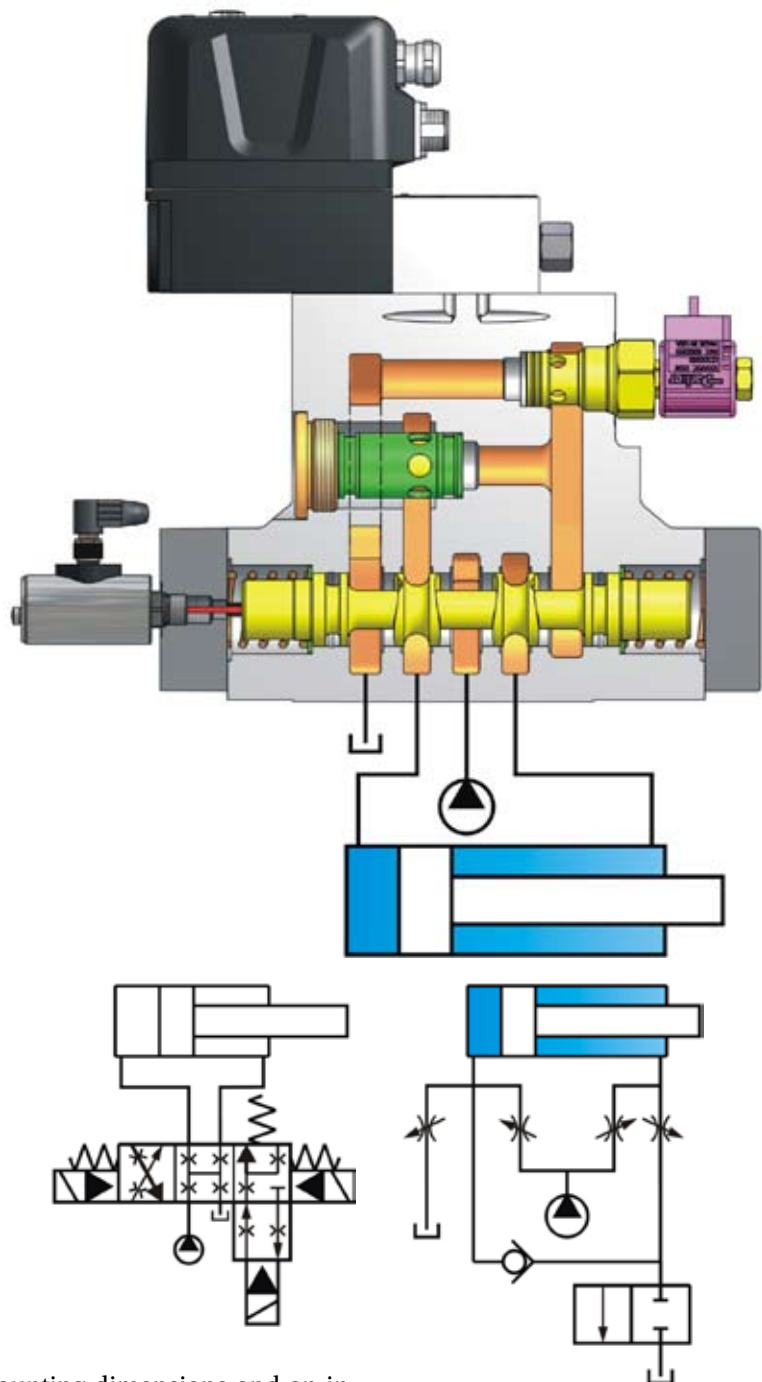

mounting dimensions and an integrated, deactivatable A-return economiser circuit reduces the oil requirement for partially-loaded differential cylinders. Switching between energy saving at partial load in the economiser circuit and high energy consumption at full load in the standard circuit can take place at any time independently of the piston stroke.

Author:

Dr.-Ing. G. Scheffel is General Manager of the Hydraulic Controls Division and Managing Director of Parker Hannifin Deutschland

Parker Worldwide

AE – UAE, Dubai
Tel: +971 4 8127100
parker.me@parker.com

AR – Argentina, Buenos Aires
Tel: +54 3327 44 4129

AT – Austria, Wiener Neustadt
Tel: +43 (0)2622 23501-0
parker.austria@parker.com

AT – Eastern Europe, Wiener Neustadt
Tel: +43 (0)2622 23501 900
parker.easteurope@parker.com

AU – Australia, Castle Hill
Tel: +61 (0)2-9634 7777

AZ – Azerbaijan, Baku
Tel: +994 50 2233 458
parker.azerbaijan@parker.com

BE/LU – Belgium, Nivelles
Tel: +32 (0)67 280 900
parker.belgium@parker.com

BR – Brazil, Cachoeirinha RS
Tel: +55 51 3470 9144

BY – Belarus, Minsk
Tel: +375 17 209 9399
parker.belarus@parker.com

CA – Canada, Milton, Ontario
Tel: +1 905 693 3000

CH – Switzerland, Etoy
Tel: +41 (0) 21 821 02 30
parker.switzerland@parker.com

CL – Chile, Santiago
Tel: +56 2 623 1216

CN – China, Shanghai
Tel: +86 21 2899 5000

CZ – Czech Republic, Klecany
Tel: +420 284 083 111
parker.czechrepublic@parker.com

DE – Germany, Kaarst
Tel: +49 (0)2131 4016 0
parker.germany@parker.com

DK – Denmark, Ballerup
Tel: +45 43 56 04 00
parker.denmark@parker.com

ES – Spain, Madrid
Tel: +34 902 33 00 01
parker.spain@parker.com

FI – Finland, Vantaa
Tel: +358 (0)20 753 2500
parker.finland@parker.com

FR – France, Contamine s/Arve
Tel: +33 (0)4 50 25 80 25
parker.france@parker.com

GR – Greece, Athens
Tel: +30 210 933 6450
parker.greece@parker.com

HK – Hong Kong
Tel: +852 2428 8008

HU – Hungary, Budapest
Tel: +36 1 220 4155
parker.hungary@parker.com

IE – Ireland, Dublin
Tel: +353 (0)1 466 6370
parker.ireland@parker.com

IN – India, Mumbai
Tel: +91 22 6513 7081-85

IT – Italy, Corsico (MI)
Tel: +39 02 45 19 21
parker.italy@parker.com

JP – Japan, Fujisawa
Tel: +(81) 4 6635 3050

KR – South Korea, Seoul
Tel: +82 2 559 0400

KZ – Kazakhstan, Almaty
Tel: +7 7272 505 800
parker.easteurope@parker.com

LV – Latvia, Riga
Tel: +371 6 745 2601
parker.latvia@parker.com

MX – Mexico, Apodaca
Tel: +52 81 8156 6000

MY – Malaysia, Shah Alam
Tel: +60 3 7849 0800

NL – The Netherlands, Oldenzaal
Tel: +31 (0)541 585 000
parker.nl@parker.com

NO – Norway, Ski
Tel: +47 64 91 10 00
parker.norway@parker.com

NZ – New Zealand, Mt Wellington
Tel: +64 9 574 1744

PL – Poland, Warsaw
Tel: +48 (0)22 573 24 00
parker.poland@parker.com

PT – Portugal, Leca da Palmeira
Tel: +351 22 999 7360
parker.portugal@parker.com

RO – Romania, Bucharest
Tel: +40 21 252 1382
parker.romania@parker.com

RU – Russia, Moscow
Tel: +7 495 645-2156
parker.russia@parker.com

SE – Sweden, Spånga
Tel: +46 (0)8 59 79 50 00
parker.sweden@parker.com

SG – Singapore
Tel: +65 6887 6300

SK – Slovakia, Banská Bystrica
Tel: +421 484 162 252
parker.slovakia@parker.com

SL – Slovenia, Novo Mesto
Tel: +386 7 337 6650
parker.slovenia@parker.com

TH – Thailand, Bangkok
Tel: +662 717 8140

TR – Turkey, Istanbul
Tel: +90 216 4997081
parker.turkey@parker.com

TW – Taiwan, Taipei
Tel: +886 2 2298 8987

UA – Ukraine, Kiev
Tel: +380 44 494 2731
parker.ukraine@parker.com

UK – United Kingdom, Warwick
Tel: +44 (0)1926 317 878
parker.uk@parker.com

US – USA, Cleveland (industrial)
Tel: +1 216 896 3000

US – USA, Lincolnshire (mobile)
Tel: +1 847 821 1500

VE – Venezuela, Caracas
Tel: +58 212 238 5422

ZA – South Africa, Kempton Park
Tel: +27 (0)11 961 0700
parker.southafrica@parker.com

Europäisches Produktinformationszentrum
Kostenlose Rufnummer: 00 800 27 27 5374
(von AT, BE, CH, CZ, DE, EE, ES, FI, FR, IE, IT, PT, SE, SK, UK)

